

Awenta PRO

RECUPERATION SYSTEMS



VENTILATION FOR EVERY SEASON



Awenta PRO





Welcome home

Awenta PRO



Dear Customers,

In order to meet your expectations related to taking care of health and the high quality of the air at your homes, as well as paying attention to the environment, we hereby present the product catalogue for the AWENTA PRO brand.

35 years of experience in the ventilation industry constituted the basis for AWENTA to start a new business chapter. A comprehensive recuperation system for buildings, called AWENTA PRO, has been developed in our Research and Development Centre (RDC), which is based on our proprietary design solutions to improve air quality and living comfort in your homes.

The basis of the system consists of the Auros, Avira and Aquila heat recovery units with a capacity from 211 m³/h to 655 m³/h. The units have been manufactured using components from renowned manufacturers such as: Knauf Industries, Recair, Ziehl-Abegg and which in combination with a thought-out proprietary design,

a range of technical solutions and attention to detail, have resulted in reliable and high-quality products.

Quiet operation, long service life and of operation are the characteristics of the AWENTA PRO air handling units, which significantly affect the of unit installation and their daily operation. AWENTA plans to systematically expand its range with new units for different types of residential buildings.

The product range of AWENTA PRO includes ventilation system components such as ducts, connectors, distribution and plenum boxes and other accessories, which together form a complete ventilation solution with heat recovery.

The AWENTA PRO products are manufactured at the AWENTA production plant in Stojadła near Warsaw, which ensures their constant availability. By applying advanced quality control procedures and using its equipment resources, AWENTA provides modern and durable products as well as comprehensive solutions for investors based on its complete commercial offer.

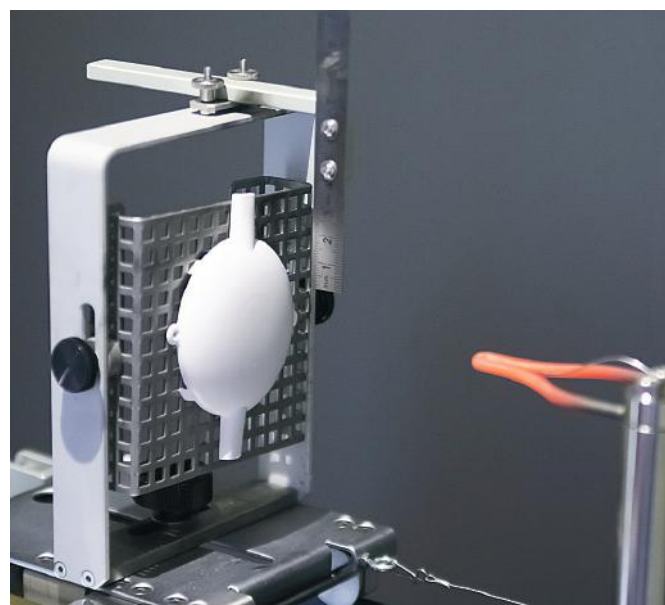



With the establishment of the **Research and Development Centre**, AWENTA has gained a tool for in-depth analysis and verification of the quality of materials and raw materials used in the production process. The company can also perform measurements of key parameters of both fans, ventilation units and the air handling units themselves.

At the heart of the RDC is its main component – the anechoic chamber. It allows for the testing of the products in terms of the noise generated. The chamber meets the stringent requirements of European directives and has been equipped with measuring equipment from renowned manufacturers, enabling measurements from 5 dB.

Manufacturing of high-quality products would not be possible without constant investment, both in the equipment resources as well as in human capital. AWENTA is steadily increasing its production capacity thanks to continuous investment.

Due to improved processes for the preparation of steel sheets, from which metal products such as ventilation grilles and inspection doors are made, the metal products have gained highly corrosion-resistant properties, which translates into an extended manufacturer's guarantee of up to 5 years. In addition, the application of new paint coatings has increased the scratch resistance of metal products to a value of 5 H (according to EN ISO 15184).

The recent investment in steel sheet processing equipment and a state-of-the-art automatic powder coating line enabled AWENTA to gain new production capacity. This has translated into the development of new product ranges or allowed the production of components for new units. In this case, an example may constitute the AWENTA PRO units designed for recuperation purposes.

The entire manufacturing process of metal products is performed exclusively by the production plant in Stojadła.

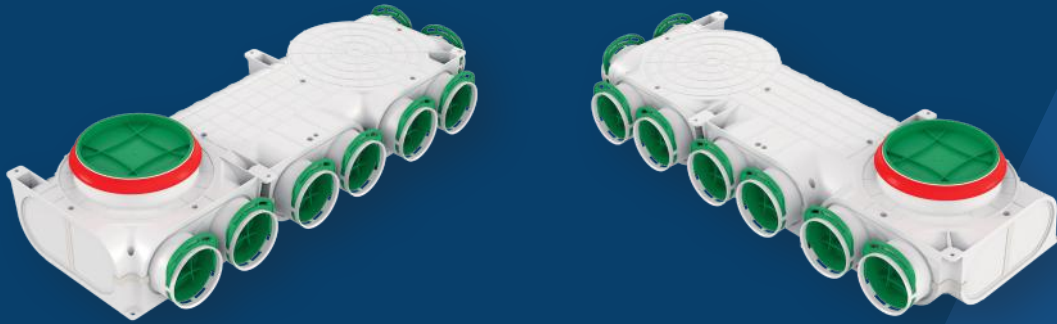

Table of contents Product catalogue 2026

NOVELTY	Arius series	8
	Auros series	12
	Avira series	16
	Aquila series - wall mounted version	20
	Aquila series - ceiling mounted version	21
	Distribution unit for Aquila heat recovery unit	24
	Enthalpy heat exchanger	25
	Filters and Pre-filters	26
	Internet module	27
	CO ₂ concentration and humidity sensor	27
	Air Quality Sensor	27
	Plenum box VPB125-2, VPB125-2/90	28
Plenum box VPB125-3	29	
NOVELTY SYSTEM Ø90	VPC series - Ceiling plenum box - horizontal	30
	VPE series - Ceiling plenum box - vertical	31
	VMK75-2-S, VMK90-2-S - Duct alternation	32
	VMK75-2-L, VMK90-2-L - Duct alternation	33
	VCB160-8, VCB200-8 - Distribution box	34
	VCB160-12, VCB200-12 - Distribution box	35
NOVELTY	VCB200-16, VCB200-16 - Distribution box	36
	VCBR series - Corner distribution box	37
	VCB125-6, VCB160-6 - Distribution box with side connector	38
	VCB160-10 - Distribution box with side connector	39
NOVELTY	VCB160-14 - Distribution box with side connector	40
	VCB160/200 - Straight-through distribution box	41
NEW MODEL	VCBR series - Corner straight-through distribution box	42
	VAK125, VAK160 - Directional diffuser	43
	VAP125 - Panel diffuser	44
	VAPO125 - Panel diffuser	45
	VCSM - Intake grilles	46
	VWSM - Exhaust grilles	47
	VFG / VFB series - Ventilation duct	48
	Circular duct Ø125 for the plenum box	49
	Circular duct Ø160 for the distribution box	49
	KO160-21 - Circular duct connector Ø160	50
	KO160-23/45 - 45° bend circular duct Ø160	50
	KO160-28 - Circular duct clamp Ø 160	50
	KO160-29 - Circular duct reductor Ø 160/150	50
	KEI - Flexible duct with thermal insulation	51
	VRP75-10G - Airflow regulator Ø 75	52
	VM75, VM90 - Coupling	52
	VZ75-5, VZ90-5 - End caps	52
	VU75-5, VU90-5 - Gaskets	52
	VNK75R, VNK75G, VNK90R, VNK90G - Duct cutters	52
	VH75-2 - Duct holder Ø 75	52
	VTA - Aluminium sealing tape	52
	VTZ - Reinforced sealing tape	52
	VTM - Mounting tape, perforated	52
	Tape for the VZO band clamp	52
	VZT - Clamps for the VZO tape	52
	Decentralized ventilation	53
	AHRP160 PLUS - Compact recuperator	56
	AHRE160 EASY - Compact recuperator	58

RECUPERATION SYSTEMS

Corner distribution boxes



Ceiling plenum boxes Ø90



Directional Diffuser Ø160



PRODUCT DATA SHEET

Arius Series

VAH305, VAH405, VAH505, VAH605

optional equipment



iNEXT

ENTHALPY
EXCHANGERCONSTANT
FLOW

MODBUS

MODULATED
HEATERENERGY
EFFICIENCY

MATERIAL

RECUPERATOR FEATURES

NOVELTY

- Installation position - wall-mounted (no brackets for wall mounting) or floor-standing
- Counterflow heat exchanger with the efficiency of up to 95%
- Energy-efficient fans with the EC Ziehl-Abegg and EBM papst motors
- Automatic bypass, 100% isolated
- Modulating preheat coil with variable operating parameters
- Excellent insulation thanks to the use of the EPP (expanded polypropylene) housing
- Leak tight structure preventing the penetration of odours and pollutants from the exhaust air into the supply air
- Mobile application for smartphones – Android, iOS and possible remote control by using webpage (iNext module required)
- Automatic flow control system (constant flow) - in CF versions
- Equipped with two filters (M5/ISO ePM10)
- Possibility of using fine filters (F7/ISO ePM1) with higher filtration class
- Possibility of using reusable pre-filter
- Possible interoperation with the air quality, carbon dioxide and humidity sensor (VSPM, VSHC, VSHW)
- Option of cleaning heat exchanger
- Long service life
- Scratch resistance of painted parts at a value of 5 H
- Animicrobial properties of painted parts according to ASTM E2149-13a
- Possible remote control via MODBUS RTU protocol

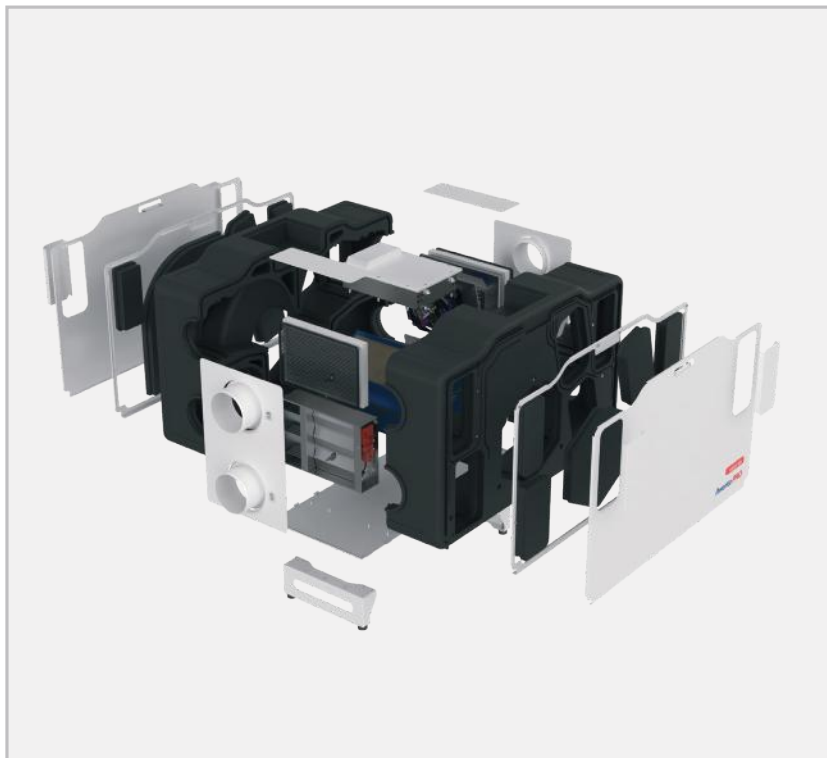

Supplementary products

FILTERS
page 26



iNEXT



ENTHALPY EXCHANGER



CONSTANT FLOW



MODBUS



MODULATED HEATER



ENERGY EFFICIENCY



MATERIAL

Arius Series

VAH305, VAH405, VAH505, VAH605

TECHNICAL INFORMATION

INDEX	ARIUS 305		ARIUS 305 Enthalpy		ARIUS 405		ARIUS 405 Enthalpy	
	VAH305		VAH305E		VAH405		VAH405E	
Supply voltage	230 V AC / 50 Hz							
IP protection class	IP33							
Preheat coil power	2 000 W							
Max. power consumption (without preheat coil)	130 W		125 W		210 W		200 W	
Capacity (at 100 Pa)	317 m ³ /h				413 m ³ /h			
Maximum engine speed	3 050 RPM		3 100 RPM		3 700 RPM		3 600 RPM	
Noise level	39 dB(A)		38 dB(A)		43 dB(A)		42 dB(A)	
Type of heat exchanger	Countercurrent		Countercurrent Enthalpy		Countercurrent		Countercurrent Enthalpy	
Max. heat recovery efficiency	up to 95%		up to 90%		up to 95%		up to 90%	
Heat exchanger material	Polystyrene							
Housing material	EPP + powder coated steel							
Filter - intake vent	VM5AH405 - M5 ISO ePM10 (optional VF7AH405 - F7 ISO ePM1)							
Filter - exhaust	VM5AH405 - M5 ISO ePM10							
Pre-filter intake / exhaust	VFWAH405 (optional)							
Diameter of air connector	160 mm							
Diameter of condensate drain connector	32 mm							
Controller type	AERO AP + AWENTA CONTROL							
Bypass	Automatic 100%							
Fans	2x radial fan with EC motor							
System Constant Flow	YES, depend on version							
Modbus RTU Communication	YES							
Internet module	VLAN iNEXT (optional)							
Air quality sensor	VSPM (optional)							
CO ₂ concentration and humidity sensor	VSHC (optional)							
Humidity sensor	VSHW (optional)							
Weight	48 kg		46 kg		48 kg		46 kg	

INDEX	ARIUS 505		ARIUS 505 Enthalpy		ARIUS 605		ARIUS 605 Enthalpy	
	VAH505		VAH505E		VAH605		VAH605E	
Supply voltage	230 V AC / 50 Hz							
IP protection class	IP33							
Preheat coil power	2 000 W							
Max. power consumption (without preheat coil)	245 W				340 W			
Capacity (at 100 Pa)	513 m ³ /h				615 m ³ /h		590 m ³ /h	
Maximum engine speed	3 900 RPM		3 850 RPM		4 400 RPM			
Noise level	43 dB(A)				45 dB(A)			
Type of heat exchanger	Countercurrent		Countercurrent Enthalpic		Countercurrent		Countercurrent Enthalpic	
Max. heat recovery efficiency	do 95%		do 90%		do 95%		do 90%	
Heat exchanger material	Polystyrene							
Housing material	EPP + powder coated steel							
Filter - intake vent	VM5AH605 - M5 ISO ePM10 (optional VF7AH605 - F7 ISO ePM1)							
Filter - exhaust	VM5AH605 - M5 ISO ePM10							
Pre-filter intake / exhaust	VFWAH605 (optional)							
Diameter of air connector	200 mm							
Diameter of condensate drain connector	32 mm							
Controller type	AERO AP + AWENTA CONTROL							
Bypass	Automatic 100%							
Fans	2x radial fan with EC motor							
System Constant Flow	YES, depend on version							
Modbus RTU Communication	YES							
Internet module	VLAN iNEXT (optional)							
Air quality sensor	VSPM (optional)							
CO ₂ concentration and humidity sensor	VSHC (optional)							
Humidity sensor	VSHW (optional)							
Weight	54 kg		52 kg		52 kg		57 kg	

PRODUCT DATA SHEET

Arius Series

VAH305, VAH405, VAH505, VAH605

optional equipment



iNEXT



ENTHALPY EXCHANGER



CONSTANT FLOW



MODBUS



MODULATED HEATER



ENERGY EFFICIENCY



MATERIAL

ARIUS - floor-standing unit



DIMENSIONS

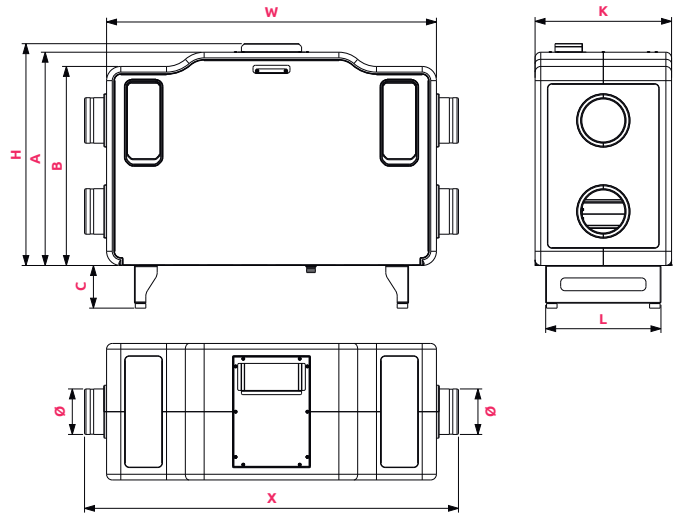

	Ø	H	A	B	K	W	X	Z	L	C
VAH305	160	780	750	700	480	1 160	1 315	25	405	150
VAH405	160	780	750	700	480	1 160	1 315	25	405	150
VAH505	200	780	750	700	580	1 160	1 313	25	505	150
VAH605	200	780	750	700	580	1 160	1 313	25	505	150

DIMENSIONS

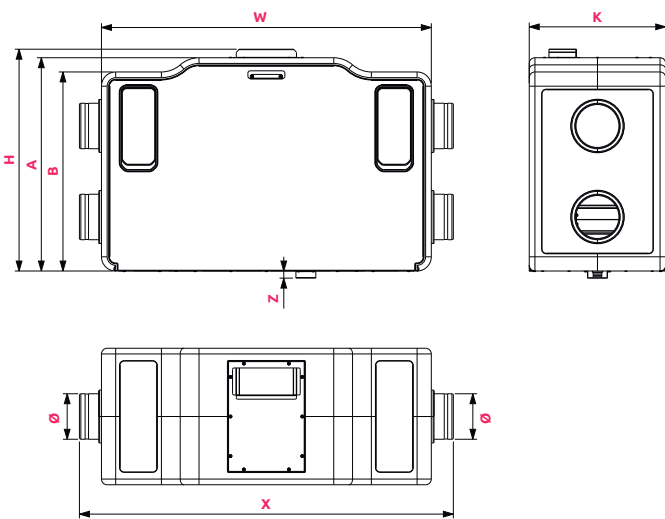

ARIUS - wall-mounted unit



PRODUCT DATA SHEET

optional equipment

Arius Series

VAH305, VAH405, VAH505, VAH605



iNEXT



ENTHALPY EXCHANGER



CONSTANT FLOW



MODBUS



MODULATED HEATER



ENERGY EFFICIENCY



MATERIAL

Arius series

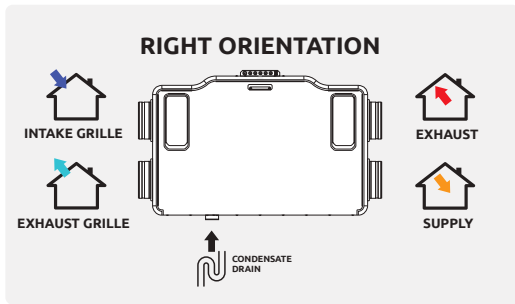
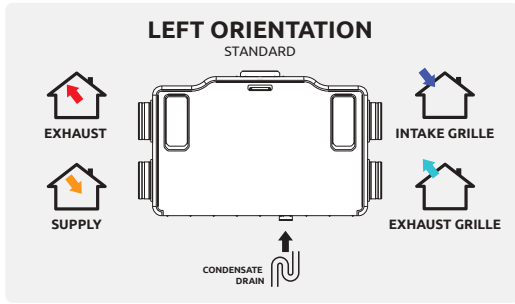

Model	Configuration	CF	Entalpy Exchanger
VAH305	Recuperator ARIUS (standard)		
VAH305E	Recuperator ARIUS (standard)		●
VAH305CF	Recuperator ARIUS (standard)	●	
VAH305CFE	Recuperator ARIUS (standard)	●	●
VAH405	Recuperator ARIUS (standard)		
VAH405E	Recuperator ARIUS (standard)		●
VAH405CF	Recuperator ARIUS (standard)	●	
VAH405CFE	Recuperator ARIUS (standard)	●	●
VAH505	Recuperator ARIUS (standard)		
VAH505E	Recuperator ARIUS (standard)		●
VAH505CF	Recuperator ARIUS (standard)	●	
VAH505CFE	Recuperator ARIUS (standard)	●	●
VAH605	Recuperator ARIUS (standard)		
VAH605E	Recuperator ARIUS (standard)		●
VAH605CF	Recuperator ARIUS (standard)	●	
VAH605CFE	Recuperator ARIUS (standard)	●	●

CAPACITY

ARIUS 305

STANDARD VERSION

ENTHALPY HEAT EXCHANGER VERSION

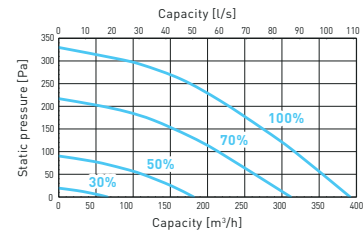
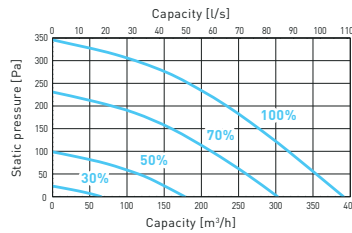

ARIUS 405

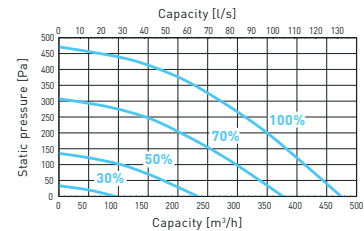
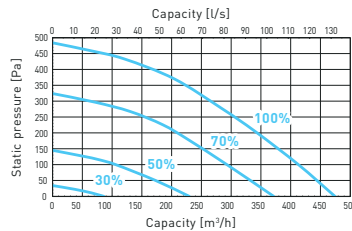

ARIUS 505

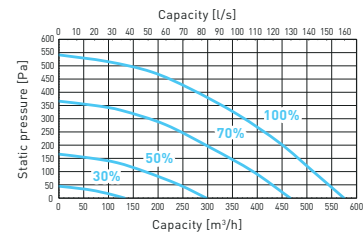
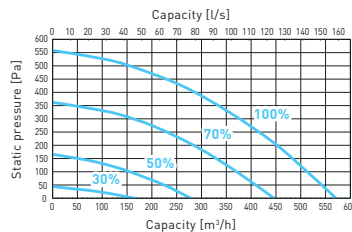

ARIUS 605

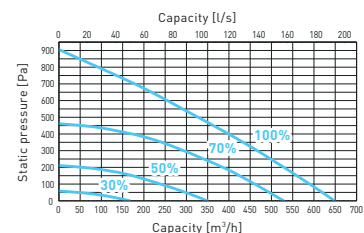
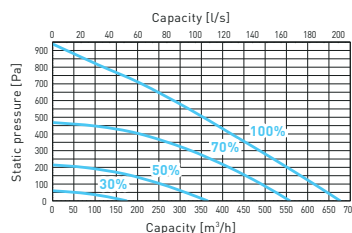

PRODUCT DATA SHEET

Auros series

VER305, VER405, VER505, VER605

optional equipment



iNEXT



ENTHALPY EXCHANGER



CONSTANT FLOW



MODBUS



MODULATED HEATER



ENERGY EFFICIENCY



MATERIAL

RECUPERATOR FEATURES

- Mounting position – wall-mounted (wall batten included) and floor-standing (VKNER legs sold separately)
- 360° rotating connection joints
- Counterflow heat exchanger with the efficiency of up to 95%
- Energy-efficient fans with the Ziehl-Abegg EC motors
- Automatic bypass, 100% bypass, isolated
- Modulating preheat coil with variable operating parameters
- Excellent insulation thanks to the use of the EPP (expanded polypropylene) housing
- Leak tight structure preventing the penetration of odours and pollutants from the exhaust air into the supply air
- Mobile application for smartphones – Android, iOS and possible remote control by using webpage (iNext module required)
- Automatic flow control system (constant flow) – in CF versions.
- Equipped with two filters (M5/ISO ePM10) as a standard
- Possibility of using fine filters (F7/ISO ePM1) with higher filtration class
- Possibility of using reusable pre-filter.
- Possible interoperation with the air quality, carbon dioxide and humidity sensor (VSPM, VSHC, VSHW)
- Option of cleaning heat exchanger
- Long service life
- Scratch resistance of painted parts at a value of 5 H
- Antimicrobial properties of painted parts according to ASTM E2149-13a

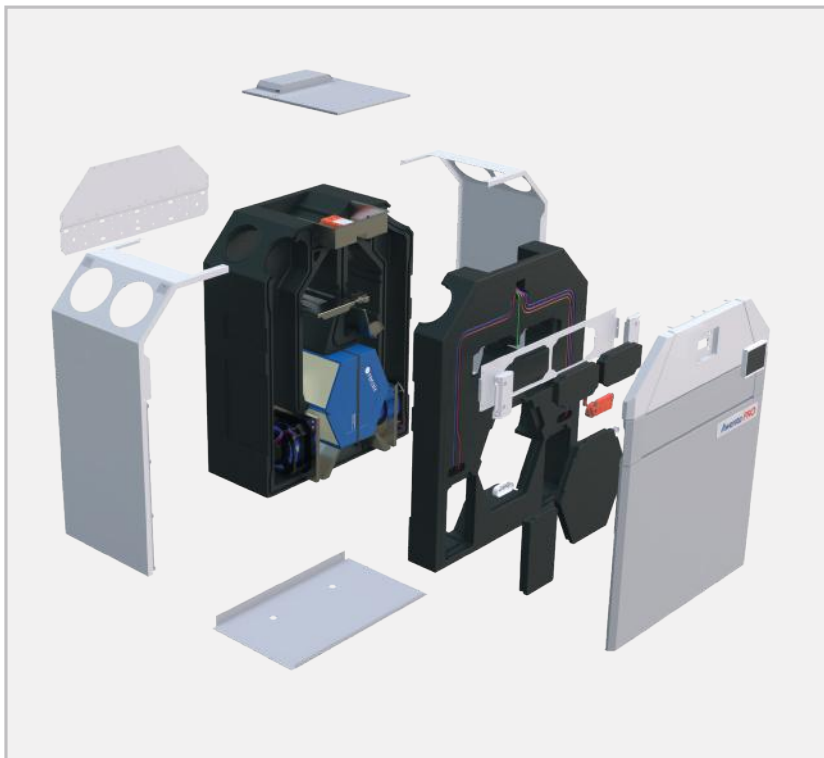

Supplementary products

LEGS
VKNER

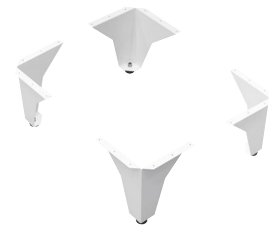

FILTERS
page 26



PRODUCT DATA SHEET

optional equipment



iNEXT



ENTHALPY EXCHANGER



CONSTANT FLOW



MODBUS



MODULATED HEATER



ENERGY EFFICIENCY



MATERIAL

Auros series

VER305, VER405, VER505, VER605

TECHNICAL INFORMATION

INDEX	AUROS 305		AUROS 305 Enthalpy		AUROS 405		AUROS 405 Enthalpy	
	VER305		VER305E		VER405		VER405E	
Supply voltage	230 V AC / 50 Hz							
IP protection class	IP33							
Preheat coil power	2 000 W							
Max. power consumption (without preheat coil)	195 W		145 W		225 W		220 W	
Capacity (at 100 Pa)	315 m ³ /h				418 m ³ /h			
Maximum engine speed	3 550 RPM		3 150 RPM		3 700 RPM		3 600 RPM	
Noise level	44 dB(A)		43 dB(A)		42 dB(A)			
Type of heat exchanger	Countercurrent		Countercurrent Enthalpy		Countercurrent		Countercurrent Enthalpy	
Max. heat recovery efficiency	up to 95%		up to 90%		up to 95%		up to 90%	
Heat exchanger material	Polystyrene							
Housing material	EPP + powder coated steel							
Filter - intake vent	VM5ER405 - M5 ISO ePM10 (optional VF7ER405 - F7 ISO ePM1)							
Filter - exhaust	VM5ER405 - M5 ISO ePM10							
Pre-filter intake / exhaust	VFWER405 (optional)							
Diameter of air connector	160 mm							
Diameter of condensate drain connector	32 mm							
Controller type	AERO AP + AWENTA CONTROL							
Bypass	Automatic 100%							
Fans	2x radial fan with EC motor							
System Constant Flow	YES, depend on version							
Modbus RTU Communication	YES							
Internet module	VLAN iNEXT (optional)							
Air quality sensor	VSPM (optional)							
CO ₂ concentration and humidity sensor	VSHC (optional)							
Humidity sensor	VSHW (optional)							
Weight	42 kg		47 kg		46 kg		44 kg	

INDEX	AUROS 505		AUROS 505 Enthalpy		AUROS 605		AUROS 605 Enthalpy	
	VER505		VER505E		VER605		VER605E	
Supply voltage	230 V AC / 50 Hz							
IP protection class	IP33							
Preheat coil power	2 000 W							
Max. power consumption (without preheat coil)	280 W		270 W		340 W			
Capacity (at 100 Pa)	515 m ³ /h				605 m ³ /h		585 m ³ /h	
Maximum engine speed	3 950 RPM		3 900 RPM		4 400 RPM			
Noise level	44 dB(A)				45 dB(A)			
Type of heat exchanger	Countercurrent		Countercurrent Enthalpy		Countercurrent		Countercurrent Enthalpy	
Max. heat recovery efficiency	up to 95%		up to 90%		up to 95%		up to 90%	
Heat exchanger material	Polystyrene							
Housing material	EPP + powder coated steel							
Filter - intake vent	VM5ER605 - M5 ISO ePM10 (optional VF7ER605 - F7 ISO ePM1)							
Filter - exhaust	VM5ER605 - M5 ISO ePM10							
Pre-filter intake / exhaust	VFWER605 (optional)							
Diameter of air connector	200 mm							
Diameter of condensate drain connector	32 mm							
Controller type	AERO AP + AWENTA CONTROL							
Bypass	Automatic 100%							
Fans	2x radial fan with EC motor							
System Constant Flow	YES, depend on version							
Modbus RTU Communication	YES							
Internet module	VLAN iNEXT (optional)							
Air quality sensor	VSPM (optional)							
CO ₂ concentration and humidity sensor	VSHC (optional)							
Humidity sensor	VSHW (optional)							
Weight	52 kg		50 kg		50 kg		56 kg	

PRODUCT DATA SHEET

optional equipment



iNEXT



ENTHALPY EXCHANGER



CONSTANT FLOW



MODBUS



MODULATED HEATER



ENERGY EFFICIENCY



MATERIAL

Auros series

VER305, VER405, VER505, VER605

AUROS - floor-standing unit



DIMENSIONS

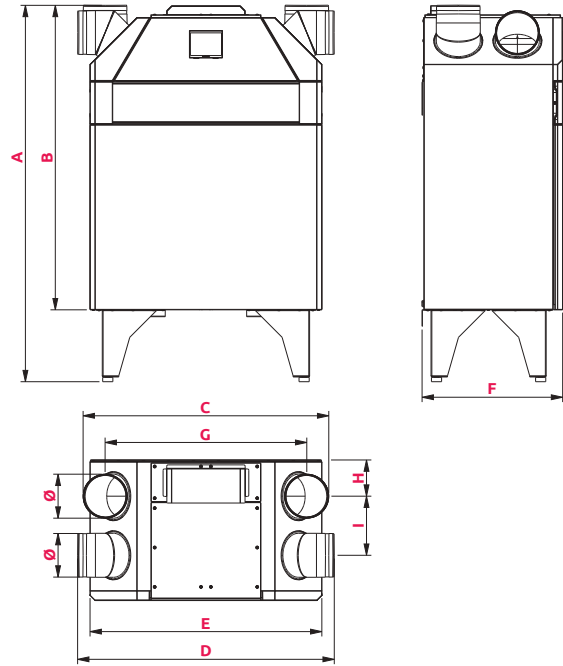

	Ø	A	B	C	D	E	F	G	H	I
VER305	160	1 370	1 108	764	804	713	510	604	132	215
VER405	160	1 370	1 108	894	934	843	510	743	132	215
VER505	200	1 377	1 115	946	962	843	610	748	147	265
VER605	200	1 377	1 115	946	962	843	610	748	147	265

DIMENSIONS

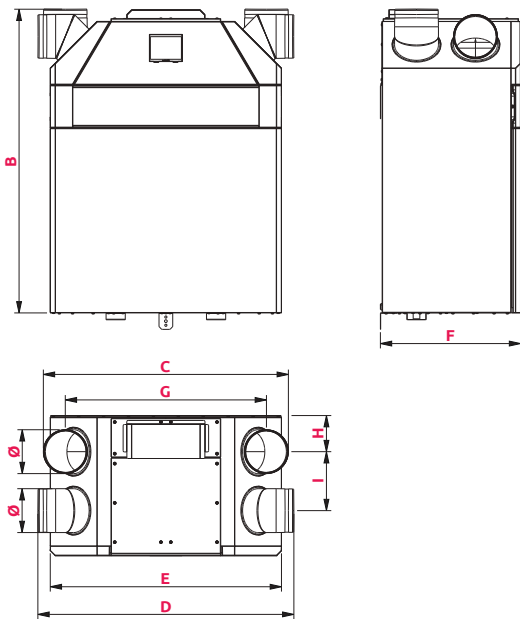

AUROS - wall-mounted unit



PRODUCT DATA SHEET

optional equipment

Auros series

VER305, VER405, VER505, VER605



iNEXT



ENTHALPY EXCHANGER



CONSTANT FLOW



MODBUS



MODULATED HEATER



ENERGY EFFICIENCY



MATERIAL

Auros series

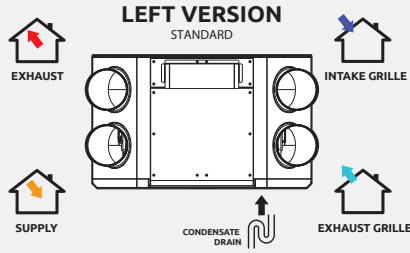

VER*L	Recuperator AUROS 305-605 left version (standard)		
VER*LE	Recuperator AUROS 305-605 left version (standard)		•
VER*LCF	Recuperator AUROS 305-605 left version (standard)	•	
VER*LCFE	Recuperator AUROS 305-605 left version (standard)	•	•

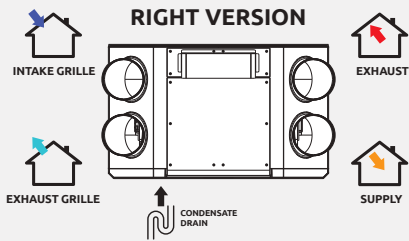

VER*P	Recuperator AUROS 305-605 right version		
VER*PE	Recuperator AUROS 305-605 right version		•
VER*PCF	Recuperator AUROS 305-605 right version	•	
VER*PCFE	Recuperator AUROS 305-605 right version	•	•



CAPACITY

STANDARD VERSION

ENTHALPY HEAT EXCHANGER VERSION

AUROS 305

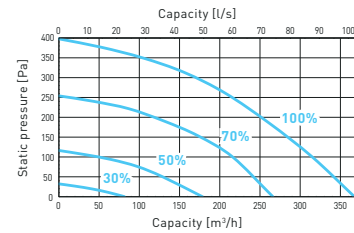
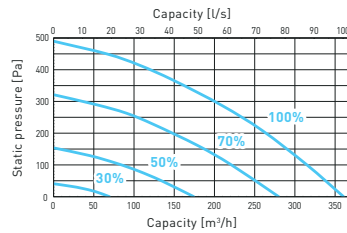

AUROS 405

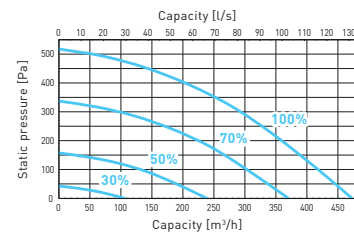
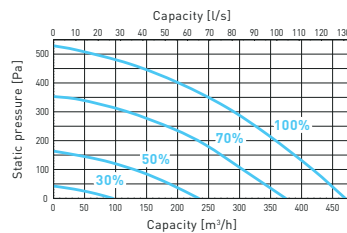

AUROS 505

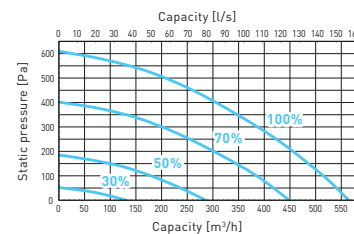
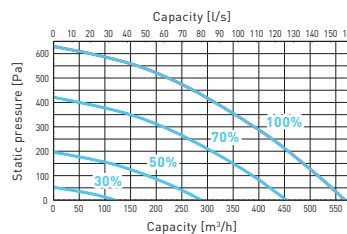

AUROS 605

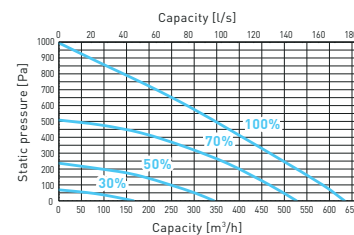
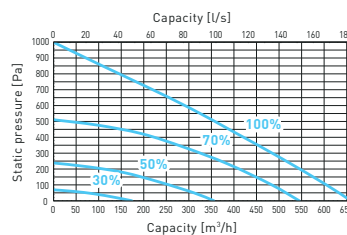

PRODUCT DATA SHEET

Avira series

VAVP305, VAVP405, VAVP505, VAVP605

optional equipment



iNEXT



ENTHALPY
EXCHANGER



CONSTANT
FLOW



MODBUS



MODULATED
HEATER



ENERGY
EFFICIENCY



MATERIAL

RECUPERATOR FEATURES

- Installation position - ceiling (suspended)
- Counterflow heat exchanger with the efficiency of up to 95%
- Energy-efficient fans with the EC Ziehl-Abegg and EBM papst motors
- Automatic bypass, 100% bypass, isolated
- Modulating preheat coil with variable operating parameters
- Excellent insulation thanks to the use of the EPP (expanded polypropylene) housing
- Leak tight structure preventing the penetration of odours and pollutants from the exhaust air into the supply air
- Mobile application for smartphones – Android, iOS and possible remote control by using webpage (iNext module required)
- Automatic flow control system (constant flow) - in CF versions
- Equipped with two filters (M5/ISO ePM10)
- Possibility of using fine filters (F7/ISO ePM1) with higher filtration class
- Possibility of using reusable pre-filter
- Possible interoperation with the air quality, carbon dioxide and humidity sensor (VSPM, VSHC, VSHW)
- Option of cleaning heat exchanger
- Long service life
- Scratch resistance of painted parts at a value of 5 H
- Antimicrobial properties of painted parts according to ASTM E2149-13a
- Possible remote control via MODBUS RTU protocol



* In the case of the recuperator AVIRA 405 with an enthalpy exchanger, an additional sensor (VSPM, VSHC, VSHW) is required to achieve energy efficiency class A.

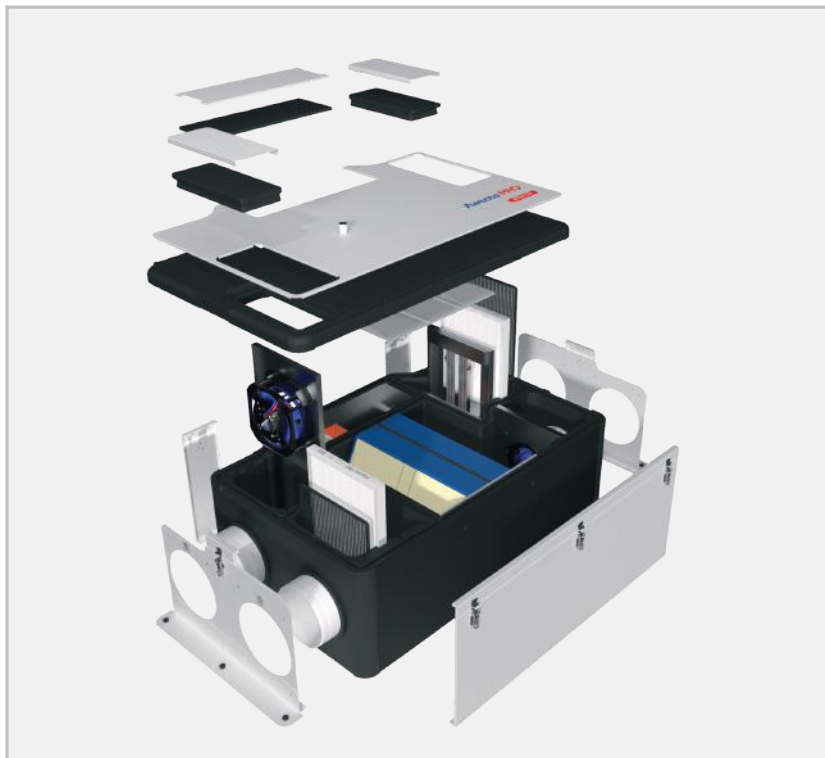

Supplementary products

FILTERS page 26



PRODUCT DATA SHEET

optional equipment



iNEXT



ENTHALPY EXCHANGER



CONSTANT FLOW



MODBUS



MODULATED HEATER



ENERGY EFFICIENCY



MATERIAL

Avira series

VAVP305, VAVP405, VAVP505, VAVP605

TECHNICAL INFORMATION

INDEX	AVIRA 305	AVIRA 305 Enthalpy	AVIRA 405	AVIRA 405 Enthalpy
	VAVP305	VAVP305E	VAVP405	VAVP405E
Supply voltage	230 V AC / 50 Hz			
IP protection class	IP33			
Preheat coil power	2 000 W			
Max. power consumption (without preheat coil)	185 W	150 W	320 W	250 W
Capacity (at 100 Pa)	315 m ³ /h		413 m ³ /h	
Maximum engine speed	3 500 RPM	3 200 RPM	3 250 RPM	3 900 RPM
Noise level	44 dB(A)	43 dB(A)	49 dB(A)	46 dB(A)
Type of heat exchanger	Countercurrent	Countercurrent enthalpy	Countercurrent	Countercurrent enthalpy
Max. heat recovery efficiency	up to 95%	up to 90%	up to 95%	up to 90%
Heat exchanger material	Polystyrene			
Housing material	EPP + powder coated steel			
Filter - intake vent	VM5AV405 - M5 ISO ePM10 (optional VF7AV405 - F7 ISO ePM1)			
Filter - exhaust	VM5AV405 - M5 ISO ePM10			
Pre-filter intake / exhaust	VFWAV405 (optional)			
Diameter of air connector	160 mm			
Diameter of condensate drain connector	32 mm			
Controller type	AERO AP + AWENTA CONTROL			
Bypass	Automatic 100%			
Fans	2x radial fan with EC motor			
System Constant Flow	YES, depend on version			
Modbus RTU Communication	YES			
Internet module	VLAN iNEXT (optional)			
Air quality sensor	VSPM (optional)			
CO ₂ concentration and humidity sensor	VSHC (optional)			
Humidity sensor	VSHW (optional)			
Weight	35 kg	39 kg	35 kg	39 kg

INDEX	AVIRA 505	AVIRA 505 Enthalpy	AVIRA 605	AVIRA 605 Enthalpy
	VAVP505	VAVP505E	VAVP605	VAVP605E
Supply voltage	230 V AC / 50 Hz			
IP protection class	IP33			
Preheat coil power	2 000 W			
Max. power consumption (without preheat coil)	275 W		400 W	365 W
Capacity (at 100 Pa)	512m ³ /h		655 m ³ /h	605 m ³ /h
Maximum engine speed	4 000 RPM		2 400 RPM	
Noise level	45 dB(A)		42 dB(A)	
Type of heat exchanger	Countercurrent	Countercurrent enthalpy	Countercurrent	Countercurrent enthalpy
Max. heat recovery efficiency	up to 95%	up to 90%	up to 95%	up to 90%
Heat exchanger material	Polystyrene			
Housing material	EPP + powder coated steel			
Filter - intake vent	VM5AV605 - M5 ISO ePM10 (optional VF7AV605 - F7 ISO ePM1)			
Filter - exhaust	VM5AV605 - M5 ISO ePM10			
Pre-filter intake / exhaust	VFWAV605 (optional)			
Diameter of air connector	200 mm			
Diameter of condensate drain connector	32 mm			
Controller type	AERO AP + AWENTA CONTROL			
Bypass	Automatic 100%			
Fans	2x radial fan with EC motor			
System Constant Flow	YES, depend on version			
Modbus RTU Communication	YES			
Internet module	VLAN iNEXT (optional)			
Air quality sensor	VSPM (optional)			
CO ₂ concentration and humidity sensor	VSHC (optional)			
Humidity sensor	VSHW (optional)			
Weight	42 kg	40 kg	40 kg	45 kg

PRODUCT DATA SHEET

Avira series

VAVP305, VAVP405, VAVP505, VAVP605

optional equipment



iNEXT



ENTHALPY EXCHANGER



CONSTANT FLOW



MODBUS



MODULATED HEATER



ENERGY EFFICIENCY



MATERIAL

AVIRA 305/405



DIMENSIONS

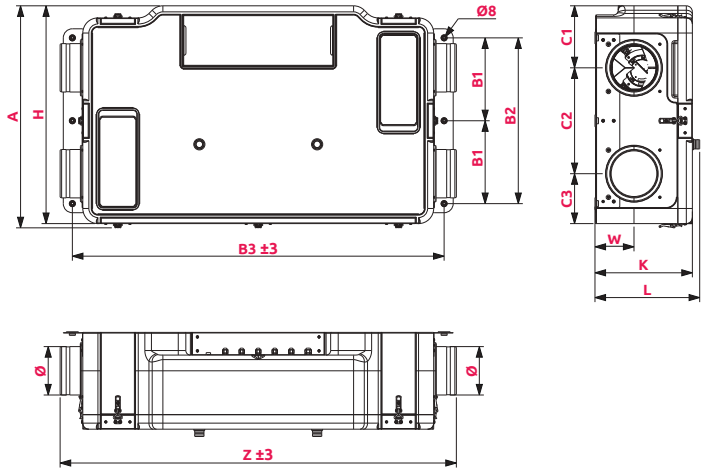

	Ø	A	H	Z	B1	B2	B3	W	K	L	C1	C2	C3
VAVP305	160	734	720	1310	274	548	1230	129	322	347	205	350	165
VAVP405	160	734	720	1310	274	548	1230	129	322	347	205	350	165
VAVP505	200	784	770	1310	289	578	1230	189	432	457	245	340	185
VAVP605	200	784	770	1310	289	578	1230	189	432	457	245	340	185

DIMENSIONS

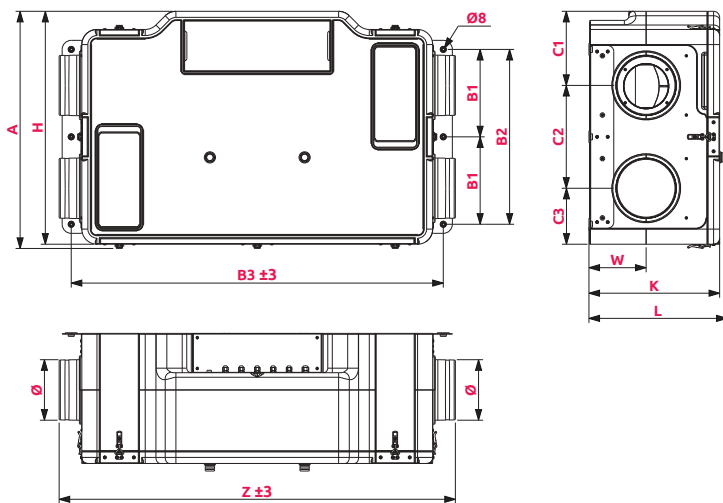

AVIRA 505/605



PRODUCT DATA SHEET

Avira series

VAVP305, VAVP405, VAVP505, VAVP605

optional equipment



iNEXT



ENTHALPY EXCHANGER



CONSTANT FLOW



MODBUS



MODULATED HEATER



ENERGY EFFICIENCY



MATERIAL

Avira series

LEFT VERSION STANDARD

VAVP*L	Recuperator AVIRA 305-605 left version (standard)		
VAVP*LE	Recuperator AVIRA 305-605 left version (standard)		●
VAVP*LCF	Recuperator AVIRA 305-605 left version (standard)	●	
VAVP*LCFE	Recuperator AVIRA 305-605 left version (standard)	●	●

RIGHT VERSION

VAVP*P	Recuperator AVIRA 305-605 right version		
VAVP*PE	Recuperator AVIRA 305-605 right version		●
VAVP*PCF	Recuperator AVIRA 305-605 right version	●	
VAVP*PCFE	Recuperator AVIRA 305-605 right version	●	●

CAPACITY

AVIRA 305

STANDARD VERSION

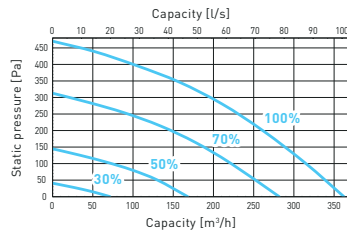

ENTHALPY HEAT EXCHANGER VERSION

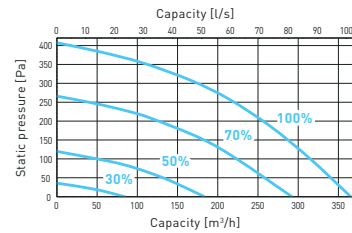

AVIRA 405

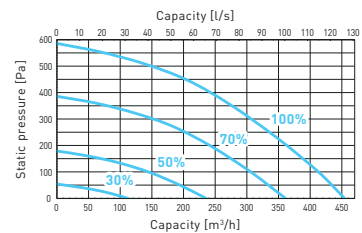
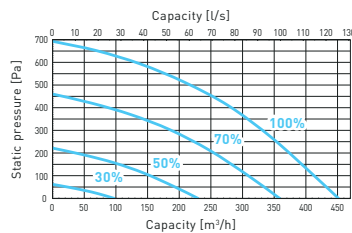

AVIRA 505

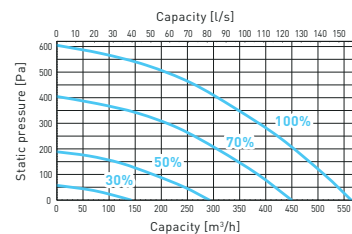
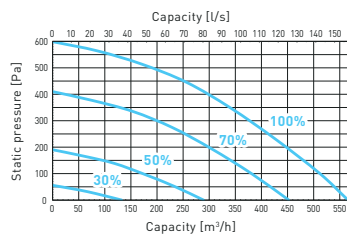

AVIRA 605

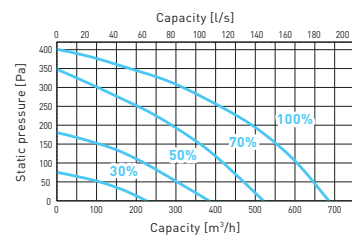
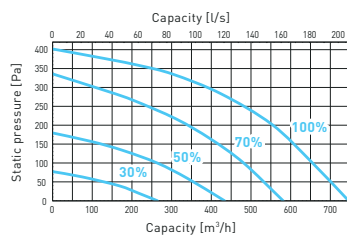

PRODUCT DATA SHEET

Aquila series
wall mounted version

VAR305

optional equipment



iNEXT

ENTHALPY
EXCHANGER

MODBUS

MODULATED
HEATERENERGY
EFFICIENCY*

EPP

RECUPERATOR FEATURES

- Installation positions – wall-mounted or floor-standing (VK-NAR feet required)
- Counter-flow heat exchanger with the efficiency of up to 95%
- Energy-saving fans with Ziehl-Abegg motors
- Automatic bypass, 100% bypass, insulated
- Excellent insulation thanks to an outer housing made of EPP (expanded polypropylene)
- Tight structure preventing odours and contaminants from the exhaust air from entering the supply air
- Wireless control available (iNext module required)
- Equipped with two filters (M5/ISO ePM10) as standard
- Option of using fine filters (F7/ISO ePM1) with a higher filtration class
- Possible use of reusable pre-filter
- Possible interoperation with the air quality, carbon dioxide and humidity sensor (VSPM, VSHC, VSHW)
- Cleanable heat exchanger
- Long service life
- Anti-freeze system
- Scratch resistance of painted parts at a value of 5 H
- Antimicrobial properties of painted elements according to ASTM E2149-13a
- Possible remote control via MODBUS RTU protocol

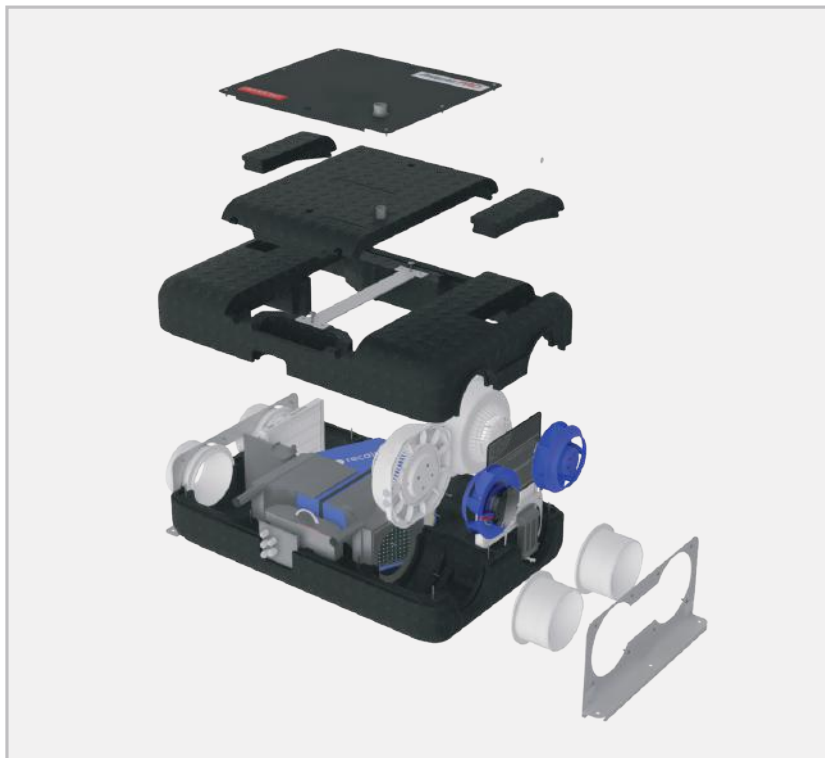

* In the case of the recuperator AQUILA 305 with an enthalpy exchanger, an additional sensor (VSPM, VSHC, VSHW) is required to achieve energy efficiency class

Supplementary
products**LEGS**
VK-NAR**FILTERS**
page 26

PRODUCT DATA SHEET

Aquila series ceiling mounted version

VARP305

optional equipment



iNEXT



ENTHALPY
EXCHANGER



MODBUS



MODULATED
HEATER



ENERGY
EFFICIENCY*



MATERIAL

RECUPERATOR FEATURES

- Installation position – ceiling mounted (suspended)
- Counter-flow heat exchanger with the efficiency of up to 95%
- Energy-saving fans with Ziehl-Abegg motors
- Automatic bypass, 100% bypass, insulated
- Excellent insulation thanks to an outer housing made of EPP (expanded polypropylene)
- Tight structure preventing odours and contaminants from the exhaust air from entering the supply air
- Wireless control available (iNext module required)
- Equipped with two filters (M5/ISO ePM10) as standard
- Option of using fine filters (F7/ISO ePM1) with a higher filtration class
- Possible use of reusable pre-filter
- Possible interoperation with the air quality, carbon dioxide and humidity sensor (VSPM, VSHC, VSHW)
- Cleanable heat exchanger
- Long service life
- Anti-freeze system
- Scratch resistance of painted parts at a value of 5 H
- Antimicrobial properties of painted elements according to ASTM E2149-13a
- Possible remote control via MODBUS RTU protocol



* In the case of the recuperator AQUILA 305 with an enthalpy exchanger, an additional sensor (VSPM, VSHC, VSHW) is required to achieve energy efficiency class

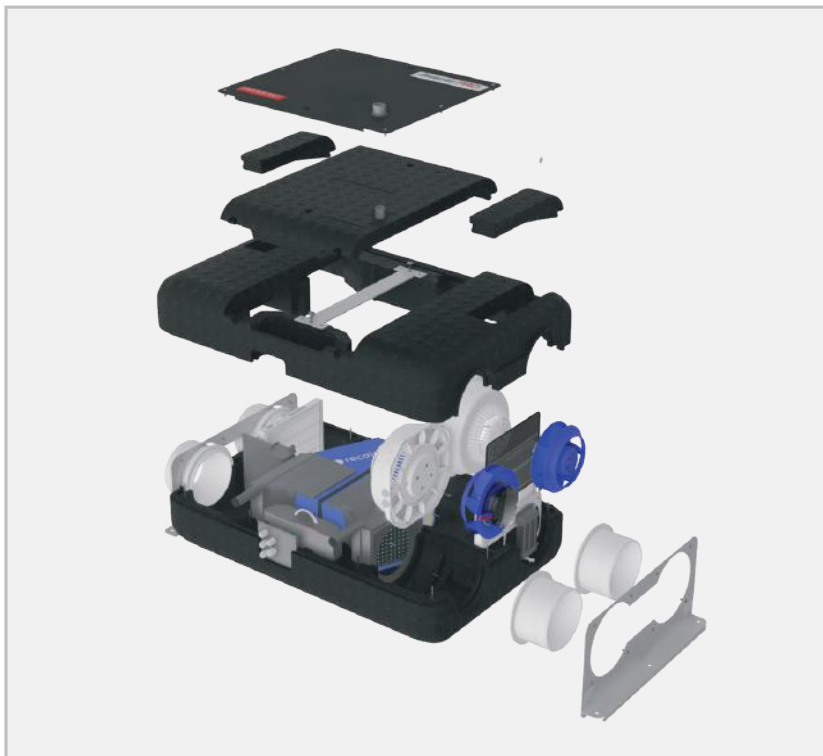

Supplementary products

FILTERS page 26



PRODUCT DATA SHEET

optional equipment



iNEXT

ENTHALPY
EXCHANGER

MODBUS

MODULATED
HEATERENERGY
EFFICIENCY*

MATERIAL

Aquila series

VAREP205, VARP305, VARES205, VARS305

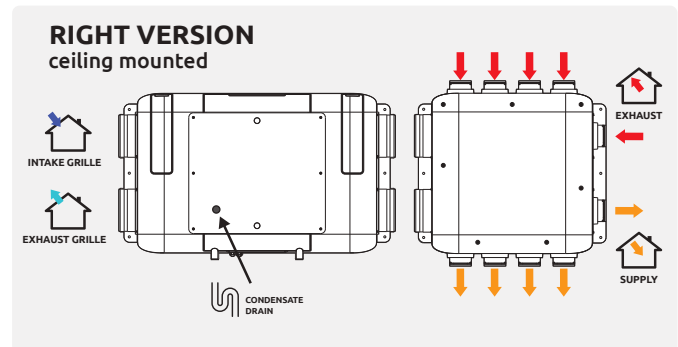
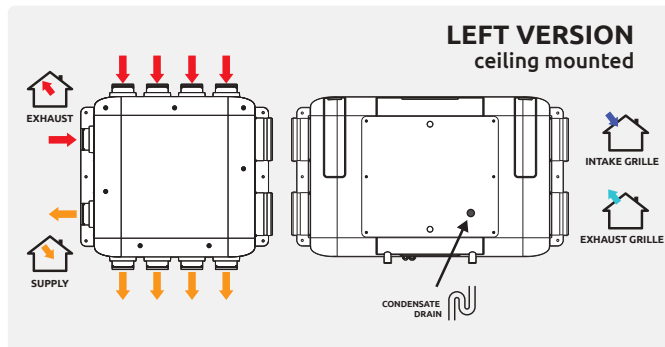
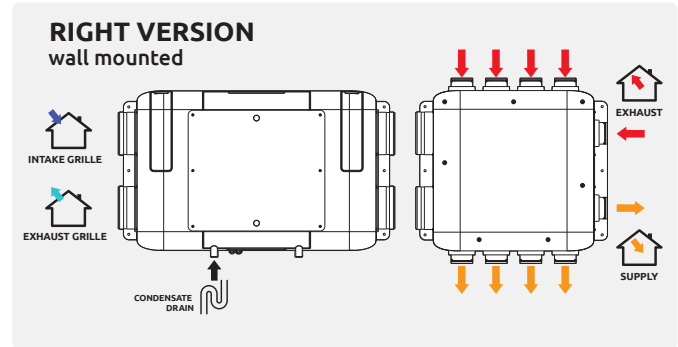
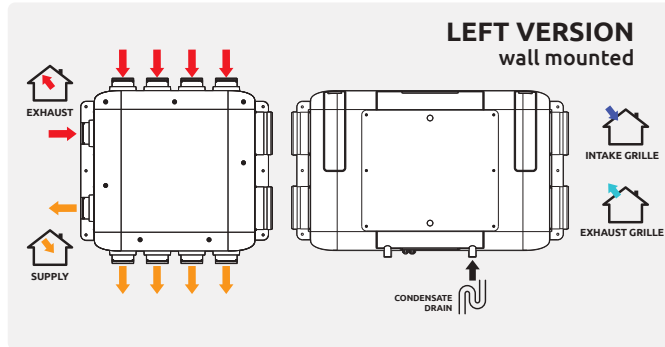

TECHNICAL INFORMATION

INDEX	AQUILA EASY 205		AQUILA 305	
	VARES205 VAREP205		VARS305 VARP305	
Supply voltage	230 V AC / 50 Hz			
IP protection class	IP22			
Preheat coil power	none		750 W	
Max. power consumption (without preheat coil)	98 W		200 W	
Capacity (at 100 Pa)	215 m ³ /h		313 m ³ /h	
Maximum engine speed	2900 RPM		3850 RPM	
Maximum Noise level	44 dB(A)		49 dB(A)	
Type of heat exchanger	Countercurrent		Countercurrent	
Max. heat recovery efficiency	up to 95%		up to 95%	
Heat exchanger material	Polystyrene			
Housing material	EPP + powder coated steel			
Filter - intake vent	M5 ISO ePM10 (optional F7 ISO ePM1)			
Filter - exhaust	M5 ISO ePM10			
Pre-filter intake / exhaust	VFWAR (optional)			
Diameter of air connector	160 mm			
Diameter of condensate drain connector	32 mm			
Controller type	AERO 6 + NANO M (monochromatic)		AERO AP + AWENTA CONTROL	
Bypass	Automatic 100%			
Fans	2x radian fan with EC motor			
Modbus RTU Communication	NO		YES	
Internet module	VLAN iNEXT (optional)			
Air quality sensor	NO		VSPM (optional)	
CO ₂ concentration and humidity sensor	NO		VSHC (optional)	
humidity sensor	NO		VSHW (optional)	
Weight	16kg + 5kg (distribution unit VARR)		16kg + 5kg (distribution unit VARR)	

PRODUCT DATA SHEET

optional equipment



iNEXT



ENTHALPY EXCHANGER



MODBUS



MODULATED HEATER



ENERGY EFFICIENCY*



MATERIAL

Aquila series

VAREP205, VARP305, VARES205, VARS305

Aquila series

AQUILA ceiling mounted version



DIMENSIONS

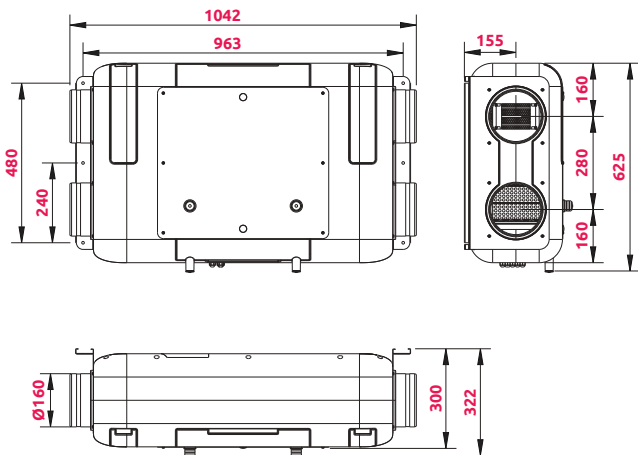
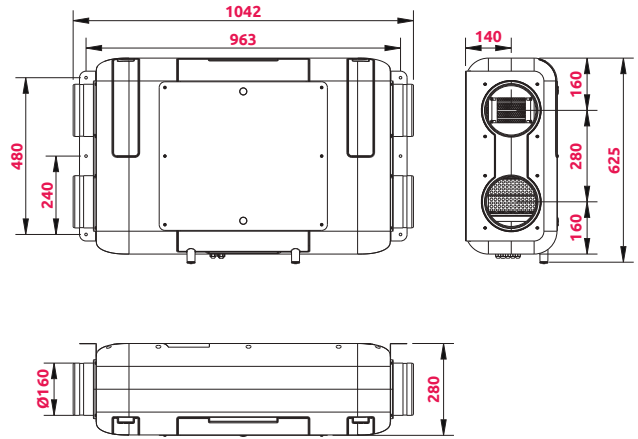

AQUILA wall mounted version



CAPACITY

STANDARD VERSION

ENTHALPY HEAT EXCHANGER VERSION

AQUILA EASY 205

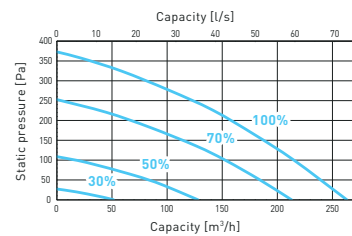
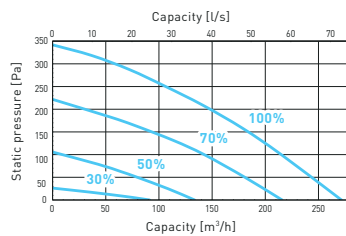

AQUILA 305

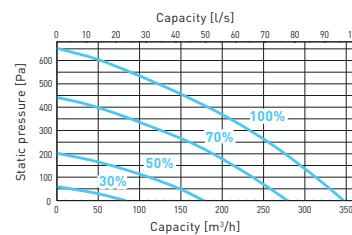
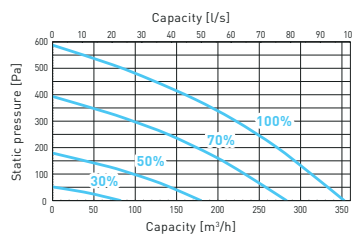

PRODUCT DATA SHEET

Distribution unit for Aquila series

VARR75-160, VARR75-160K, VARR90-160, VARR90-160K

- Dedicated distribution unit for the Aquila series heat recovery units, connection of up to 10 ducts
- Ø75 mm (5 supply ducts + 5 exhaust ducts). It is used to distribute the supply air and collect used air from rooms connected to the recuperation system
- The distribution unit can be combined with the air handling unit or moved to any suitable location and connected by means of ventilation ducts Fi160 (version VARR75-160K)
- The distribution unit housing is made of EPP (expanded polypropylene), which has a significant effect on the volume level by absorbing vibrations
- The product is of the highest tightness class (D), insulating heat perfectly while being stable over a wide temperature range (from -40°C to +60°C). What is more important, expanded polypropylene is not conducive to mould and mildew
- The distribution unit is compatible with the left and right versions of the heat recovery unit. The spigot diameter of the unit is Ø160 mm
- The distribution unit replaces the traditional distribution box



	Ø	A	B	H	W	Z	X	Y
VARR75-160	75	718	663	693	1 623	1 564	140	693
VARR75-160K	75	718	663	693	1 623	1 564	140	693
VARR90-160	90	733	663	724	1 639	1 564	140	724
VARR90-160K	90	733	663	724	1 639	1 564	140	724

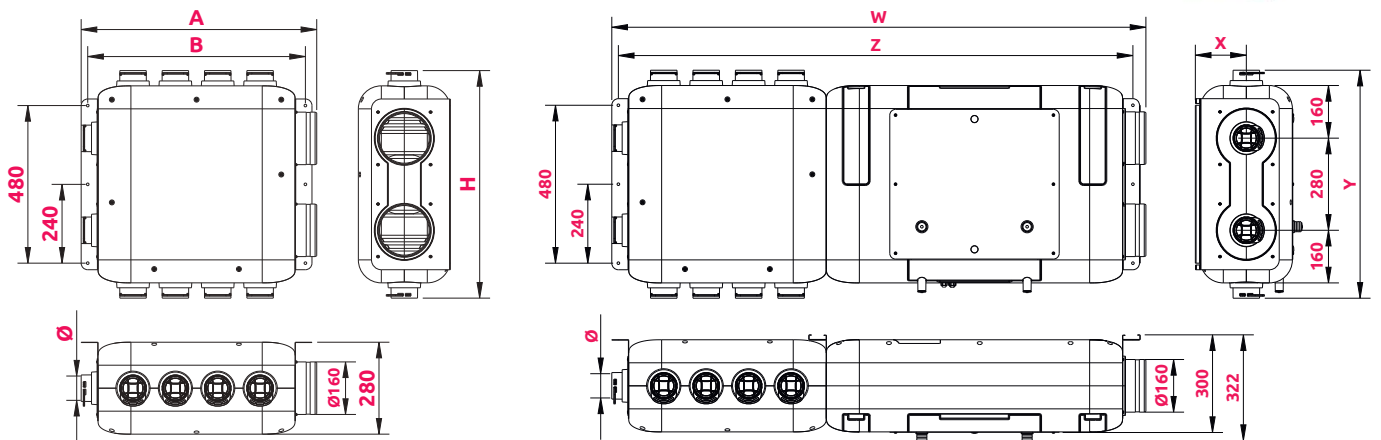

CAPACITY

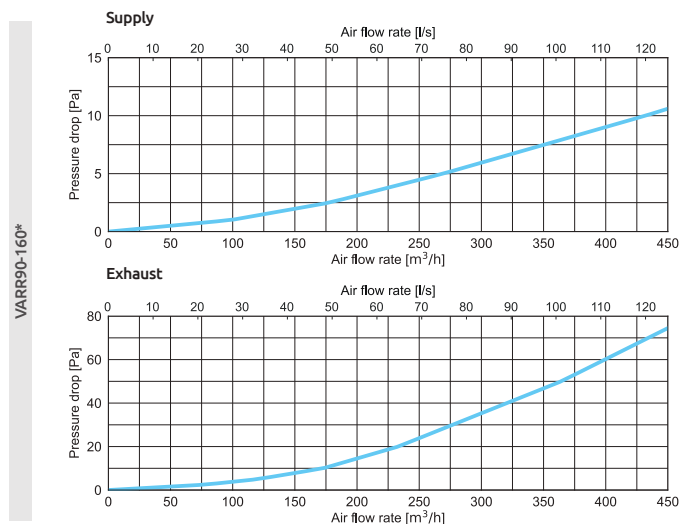
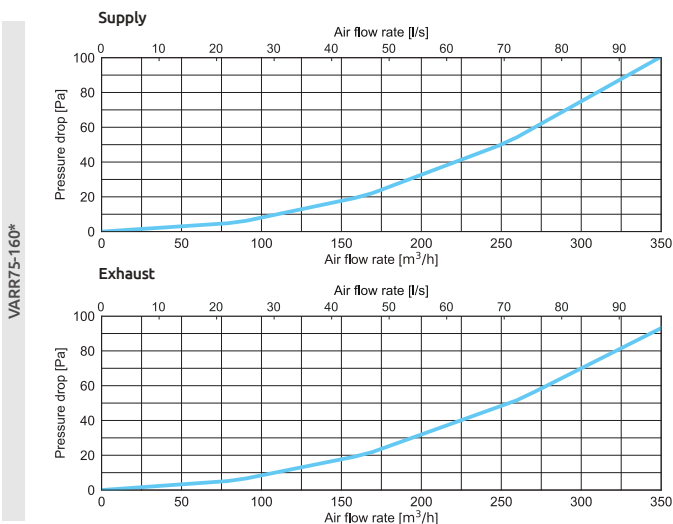

Enthalpy heat exchanger

Enthalpy heat exchangers allow the simultaneous recovery of heat and moisture from the exhaust air. The main difference between an enthalpy heat exchanger and a standard heat exchanger is the use of polymeric membrane technology. This innovative membrane enables the transfer of energy and at the same time prevents cross-contamination with viruses, gases and volatile organic compounds. Exhaust and supply air pass through the enthalpy heat exchanger channels in opposite directions. The application of osmosis principles served to efficiently transfer moisture through the pore structures present in the polymer membrane in an efficient and hygienic manner.



COMPATIBILITY

HRU type	Option of using enthalpy heat exchanger
ARIUS VAH305	•
ARIUS VAH405	•
ARIUS VAH505	•
ARIUS VAH605	•
AUROS VER305	•
AUROS VER405	•
AUROS VER505	•
AUROS VER605	•
AVIRA VAVP305	•
AVIRA VAVP405	•
AVIRA VAVP505	•
AVIRA VAVP605	•
AQUILA VARS305	•
AQUILA VARP305	•

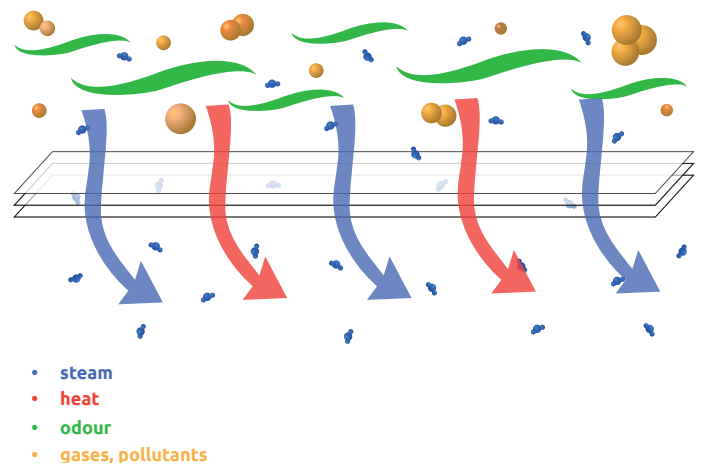
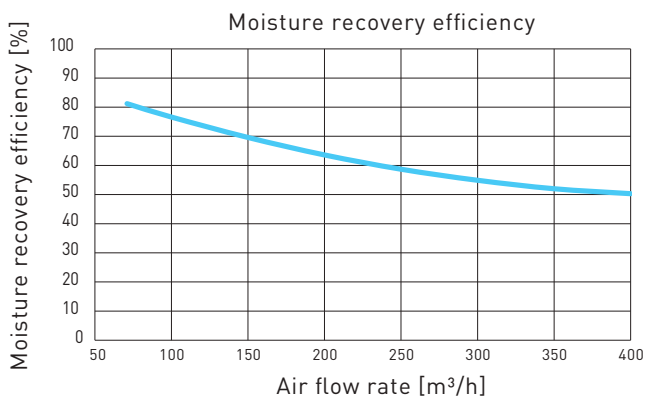
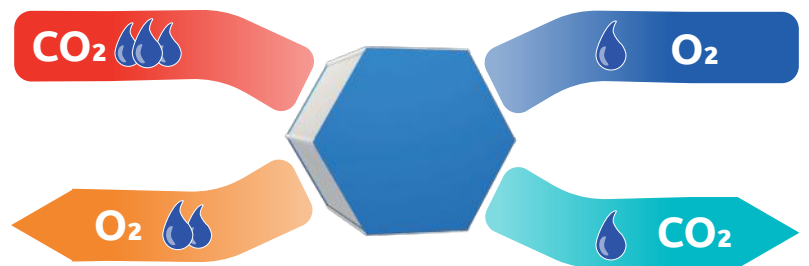

PRODUCT DATA SHEET

Filters and Pre-filters

The AWENTA PRO air handling units are equipped as standard with high-quality M5 class air filters (ISO 16890 standard) capable of removing particles with sizes from 2.5 to 10 µm (microns), e.g.: particulates and fine dust (the thickness of human hair is from 40 to 120 µm).

For air drawn in from the outside, an F7 class filter, which removes the smallest particles from 0.3 to 1 µm, e.g.: viruses, cigarette smoke, bacteria, fungi and their spores, can be installed. Dirty filters reduce air flow, increase resistance in the system and electricity consumption. In practice, this means that the efficiency of the system will be lower, as the amount of air exchanged will be lower than desired, with a consequent negative impact on well-being. Therefore, it is important to replace them regularly.

To extend the life of the M5 or F7 class main filters used in air handling units, it is possible to install an additional pre-filter. The task of the pre-filter is to stop dust and particles of large size. This ensures that only small particles reach the main filter and do not cause it to wear out quickly. The pre-filters have a cassette design, making them easy to remove for cleaning or replacement.

In case of pre-filter with nylon mesh as filter material, there is no need to replace it. The material used allows to be cleaned multiple times.

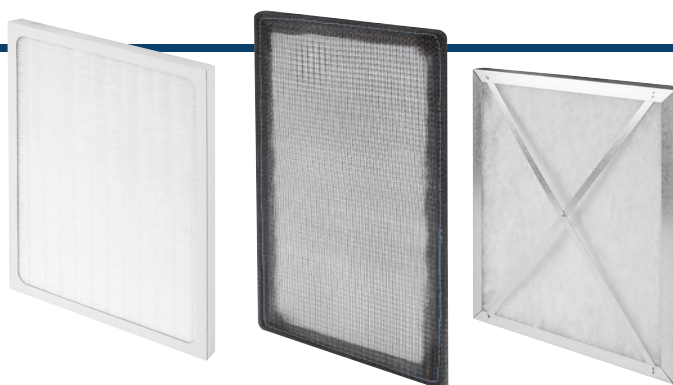

ARIUS / AUROS / AVIRA / AQUILA

ZEPHYR

COMPATIBILITY

FILTERS

Index	Filter class	Intended use
VM5AH405	M5	ARIUS VAH305, VAH405
VF7AH405	F7	ARIUS VAH305, VAH405
VM5AH605	M5	ARIUS VAH505, VAH605
VF7AH605	F7	ARIUS VAH505, VAH605
VM5ER405	M5	AUROS VER305, VER405
VF7ER405	F7	AUROS VER305, VER405
VM5ER605	M5	AUROS VER505, VER605
VF7ER605	F7	AUROS VER505, VER605
VM5AV405	M5	AVIRA VAVP305, VAVP405
VF7AV405	F7	AVIRA VAVP305, VAVP405
VM5AV605	M5	AVIRA VAVP505, VAVP605
VF7AV605	F7	AVIRA VAVP505, VAVP605
VM5AR	M5	VAR305, VARP305
VF7AR	F7	VAR305, VARP305
VM5ZH	M5	ZEPHYR VZH405, VZH605
VF7ZH	F7	ZEPHYR VZH405, VZH605

PREFILTER

Index	Filter class	Intended use
VFWAH405	unclassified	ARIUS VAH305, VAH405
VFWAH605	unclassified	ARIUS VAH505, VAH605
VFWER405	unclassified	AUROS VER305, VER405
VFWER605	unclassified	AUROS VER505, VER605
VFWAV405	unclassified	AVIRA VAVP305, VAVP405
VFWAV605	unclassified	AVIRA VAVP505, VAVP605
VFWAR	unclassified	VAR305, VARP305
VFWZH	G2	ZEPHYR VZH405, VZH605

TECHNICAL DATA

	F7	M5
Filter class	tested according to ISO 16890 Filter F7 (ePM1 0,3-1,0 µm)	tested according to ISO 16890 Filter M5 (ePM10 2,5-10 µm)
Fire protection	DIN 53438-3 (F1)	DIN 53438-3 (F1)
Maximum relative humidity	100%	100%
Temperature resistance	max. 80°C	max. 80°C
Filter materials	Glass-fibre paper	Glass-fibre paper
Frame	Cardboard	Cardboard

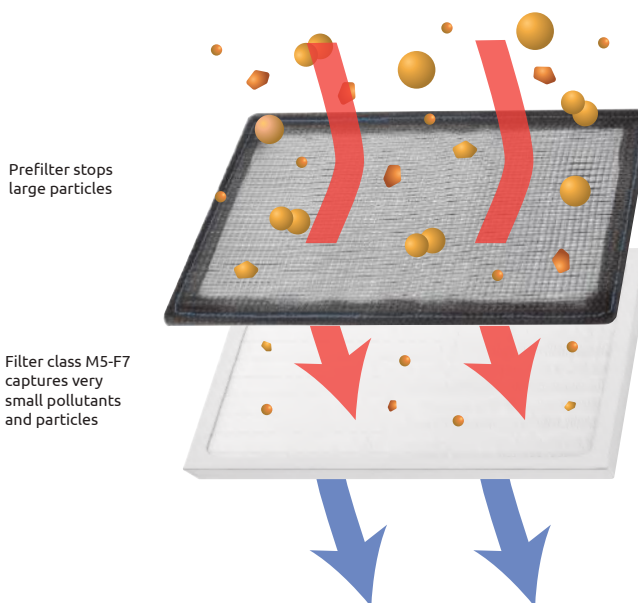

Prefilter stops large particles

Filter class M5-F7 captures very small pollutants and particles

PRODUCT DATA SHEET

CO₂, humidity and air quality sensors

VSHC, VSHW, VSPM



CO₂



HUMIDITY



AIR QUALITY

The VSHC sensor is designed to measure the concentration of carbon dioxide and humidity in rooms. When the set value of carbon dioxide concentration and humidity is exceeded, the capacity of the air handling unit is automatically increased.

The VSHW sensor is designed to measure the humidity in rooms. When the set humidity value is exceeded, the air handling unit's capacity is automatically increased.

The VSPM air quality sensor is used to measure carbon dioxide content and the amount of PM1, PM2.5, PM4 and PM10 particles. Additionally, it measures relative humidity and room temperature.

The devices can operate in the temperature range of 0°C-55°C.



VSHC
VSHW

VSPM

COMPATIBILITY

HRU type	Intended use
ARIUS VAH305	•
ARIUS VAH405	•
ARIUS VAH505	•
ARIUS VAH605	•
AUROS VER305	•
AUROS VER405	•
AUROS VER505	•
AUROS VER605	•
AVIRA VAVP305	•
AVIRA VAVP405	•
AVIRA VAVP505	•
AVIRA VAVP605	•
AQUILA VARS305	•
AQUILA VARP305	•

VSHC, VSHW

HUMIDITY MEASUREMENT

Humidity measurement range	0-100% (Note: Humidity measurement is only possible at temperatures between 0°C-55°C)
Humidity reading accuracy	±3%

VSHC

CARBON DIOXIDE MEASUREMENT

Carbon dioxide concentration measurement range	400 – 2000 ppm (Note: carbon dioxide concentration measurement is possible in the temperature range of 0°C-50°C)
Carbon dioxide reading accuracy	±3% + ±50 ppm (Note: the CO ₂ sensor is equipped with an automatic calibration algorithm)

Internet module

VLAN

VLAN is an integrated network communication system that uses the C14 communication protocol and a special Internet module. The module allows monitoring and remote control of the air handling unit's settings.

VLAN module (iNEXT) enables:

- remote communication via a web browser and via a mobile application with all Awenta PRO air handling units
- reading of current control panel parameters (e.g.: reading from temperature sensors)
- capacity control of the air handling unit (speed change, ventilation mode)
- programming weekly operating schedule
- remote access to all user settings
- remote access to service settings for the installer
- bypass flap control

To ensure communication with the Internet, it is necessary to connect the module to an access device with an Ethernet connection – such as a router or 3G/4G/5G mobile network modem.



COMPATIBILITY

HRU type	Access through the App (Android, iOS)	Access through the webpage
ARIUS VAH305-605	•	•
AUROS VER305-605	•	•
AVIRA VAVP305-605	•	•
AQUILA VARS305	•	•
AQUILA VARP305	•	•

PRODUCT DATA SHEET

TIGHTNESS
CLASS

MATERIAL



BACTERIOSTATIC

Plenum Box

VPB125-2, VPB125-2/90

The AWENTA PRO plenum box is used to connect two flexible ducts to the distribution boxes. Thanks to the possibility of supplying two ducts, it is recommended for mounting air valves in rooms requiring balanced ventilation intended for daytime stays or bedrooms.

The AWENTA PRO plenum boxes are made of durable HDPE (High Density Polypropylene) with a bacteriostatic Nano-Silver additive. The robust structure guarantees failure-free operation for many years and thanks to the use of a bacteriostatic additive the product has obtained a very high level of bacteriostatic activity. The design of the plenum box allows it to be mounted on different surfaces and in different planes. The $\varnothing 75$ or $\varnothing 90$ mm female connectors are equipped with a gasket and special protection of the connected ducts, which ensures the tightness of the entire system in the high ATC1 class. Mounting of the box is facilitated by brackets allowing for the installation height adjustment that adapts to the place of installation. They guarantee the quick and easy installation of the plenum boxes in the system. The box allows for connecting a maximum of two $\varnothing 75$ or $\varnothing 90$ mm ventilation ducts to a supply or exhaust air valve.

It is possible to install them on floor / wall / ceiling:
made of concrete or plasterboard.



VPB125-2

VPB125-2/90

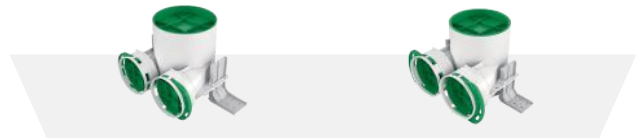

AIR FLOW CHARACTERISTICS

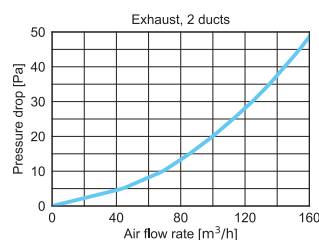
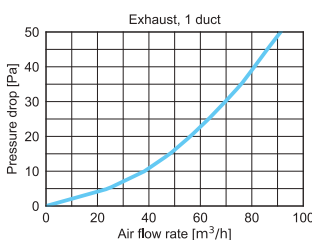
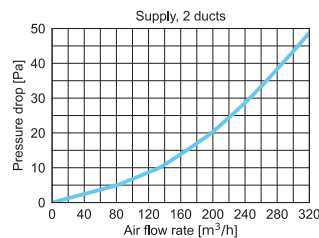
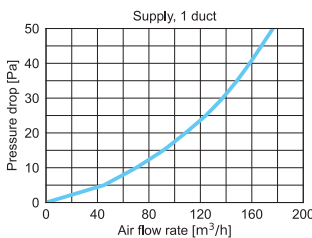
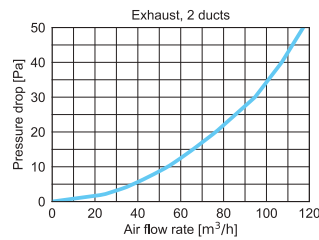
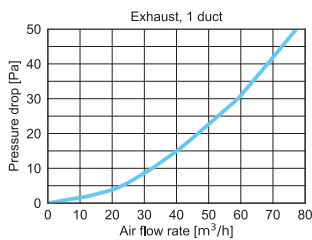
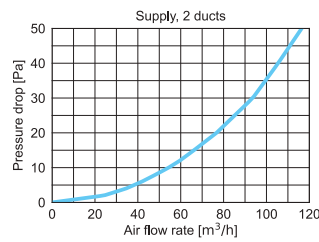
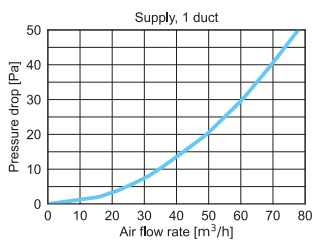

DIMENSIONS

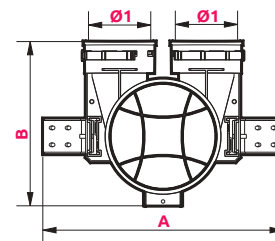
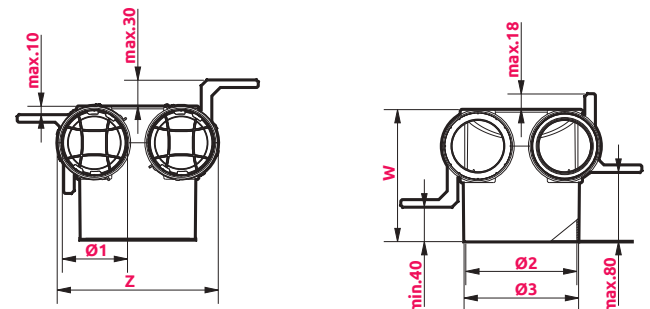

	$\varnothing 1$	$\varnothing 2$	$\varnothing 3$	A	B	Z	W
VPB125-2	75	128	134	277	189	186	152
VPB125-2/90	90	128	134	288	202	200	158

WITH **NANOSILVER** ADDITIVE
ELIMINATING UP TO 99% BACTERIA





TIGHTNESS CLASS



MATERIAL



BACTERIOSTATIC

Plenum Box

VPB125-3

The AWENTA PRO VPB125-3 plenum box is used to connect three flexible air ducts to the distribution boxes. Thanks to the possibility of supplying up to three ducts, it is recommended for mounting air valves in rooms requiring intensive ventilation, e.g. kitchen, bathroom or toilet. The high air flow efficiency of the VPB125-3 box makes it possible to achieve increased ventilation parameters without having to drill additional holes in the ceiling.

The AWENTA PRO plenum boxes are made of durable HDPE (High Density Polypropylene) with a bacteriostatic Nano-Silver additive. The robust structure guarantees failure-free operation for many years and thanks to the use of a bacteriostatic additive the product has obtained a very high level of bacteriostatic activity.

The design of the plenum box allows it to be mounted on different surfaces and in different planes. The Ø75 mm female connectors are equipped with a gasket and special protection of the connected ducts, which ensures the tightness of the entire system in the high ATC1 class. Mounting of the box is facilitated by brackets allowing for the installation height adjustment that adapts to the place of installation. They guarantee the quick and easy installation of the plenum boxes in the system.

It is possible to install them on floor / wall / ceiling:
made of concrete or plasterboard.



AIR FLOW CHARACTERISTICS

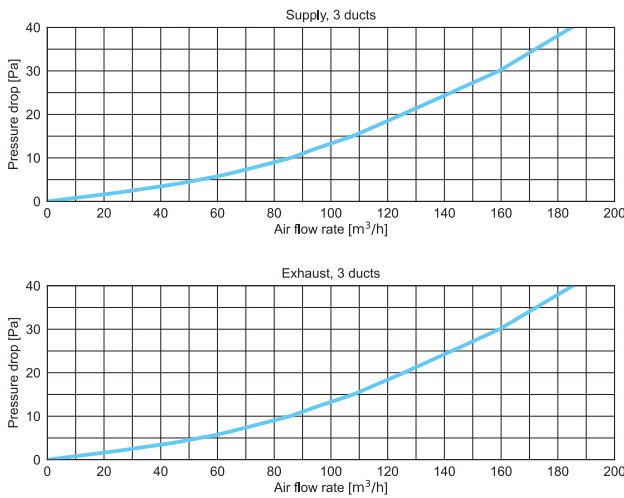

DIMENSIONS

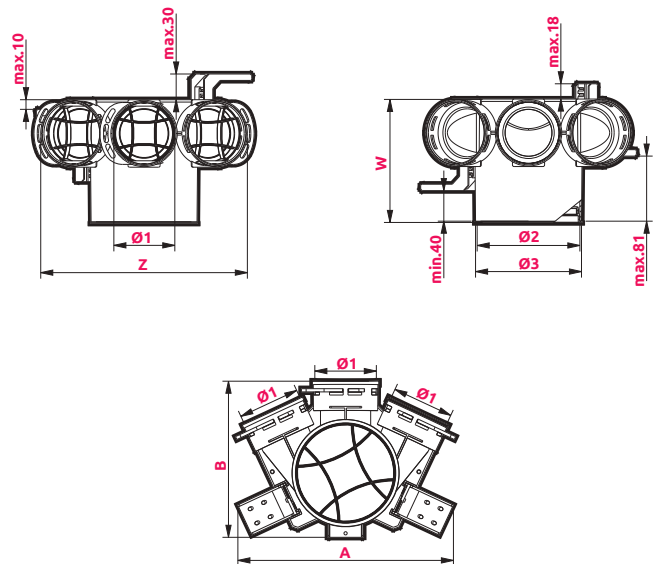

	Ø1	Ø2	Ø3	A	B	Z	W
VPB125-3	75	128	134	268	195	257	152

WITH **NANOSILVER** ADDITIVE
ELIMINATING UP TO 99% BACTERIA



PRODUCT DATA SHEET



Ceiling plenum box - horizontal

VPC125-2, VPC160-2/90

The AWENTA PRO VPC ceiling plenum box (horizontal) is an ultra-lightweight solution for use between a suspended ceiling, a ceiling or wall, and in other confined space locations. The box allows for connecting a maximum of two $\varnothing 75 - \varnothing 90$ mm ventilation ducts to a supply or exhaust air valve.

AWENTA PRO plenum boxes are made of durable modified polypropylene material. The robust structure guarantees failure-free operation for many years and thanks to the use of a bacteriostatic additive the product has obtained a very high level of bacteriostatic activity. The design of the plenum box allows it to be mounted on different surfaces and in different planes.

The $\varnothing 75 - \varnothing 90$ mm female connectors are equipped with a gasket and special protection of the connected ducts, which ensures the tightness of the entire system in the high ATC1 class.

NOVELTY SYSTEM $\varnothing 90$



VPC125-2

VPC160-2/90

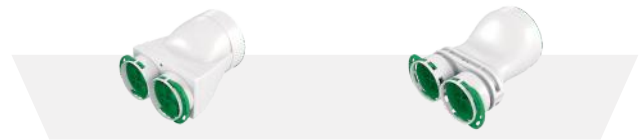

AIR FLOW CHARACTERISTICS

VPC125-2

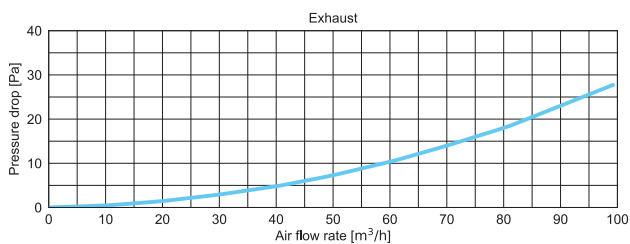

VPC160-2/90

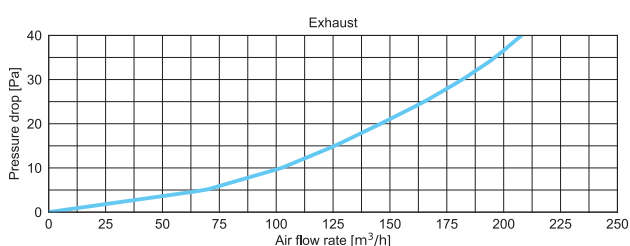
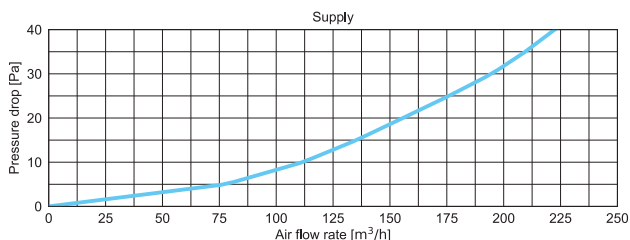

DIMENSIONS

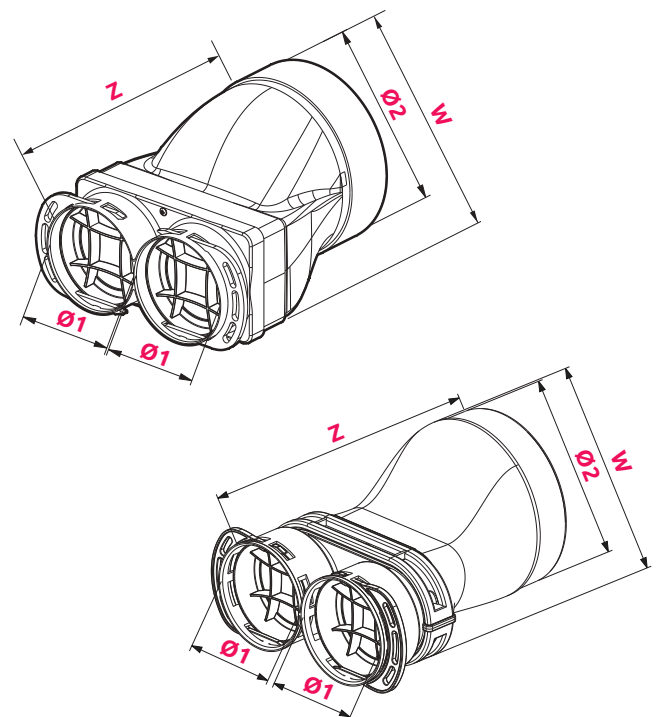

	$\varnothing 1$	$\varnothing 2$	Z	W
VPC125-2	75	128	194	134
VPC160-2/90	90	160	246	163

WITH **NANOSILVER** ADDITIVE
ELIMINATING UP TO **99%** BACTERIA



Ceiling plenum box – vertical

VPE125-2, VPE160-2/90

The AWENTA PRO VPE ceiling plenum box (vertical) is an ultra-lightweight solution for use between a suspended ceiling, a ceiling or wall, and in other confined space locations. The box allows for connecting a maximum of two Ø75 - Ø90 mm ventilation ducts to a supply or exhaust air valve.

AWENTA PRO plenum boxes are made of durable modified polypropylene material. The robust structure guarantees failure-free operation for many years and thanks to the use of bacteriostatic additive the product has obtained 99.99% bacteriostatic activity. The design of the plenum box allows it to be mounted on different surfaces and in different planes.

The Ø75 - Ø90 mm female connectors are equipped with a gasket and special protection of the connected ducts, which ensures the tightness of the entire system in the high ATC1 class.

It is possible to install them on floor / wall / ceiling: made of concrete or plasterboard.

NOVELTY SYSTEM Ø90



VPE125-2

VPE160-2/90



AIR FLOW CHARACTERISTICS

VPE125-2

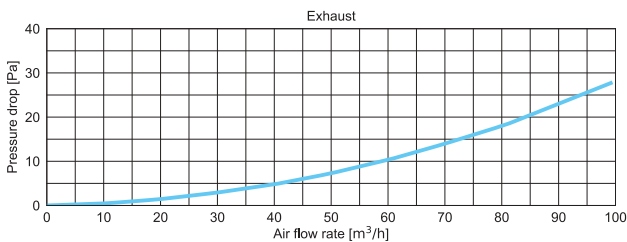
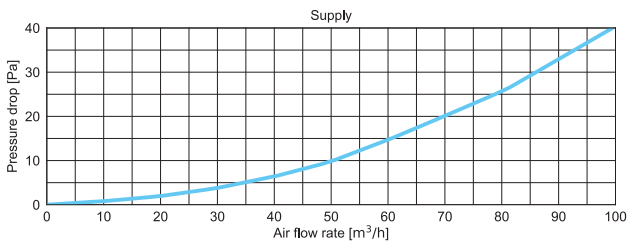

VPE160-2/90

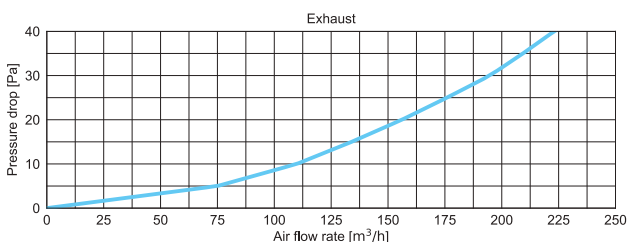
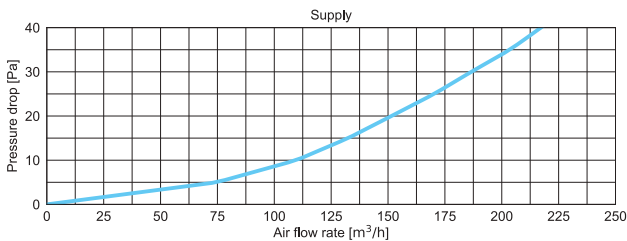

DIMENSIONS

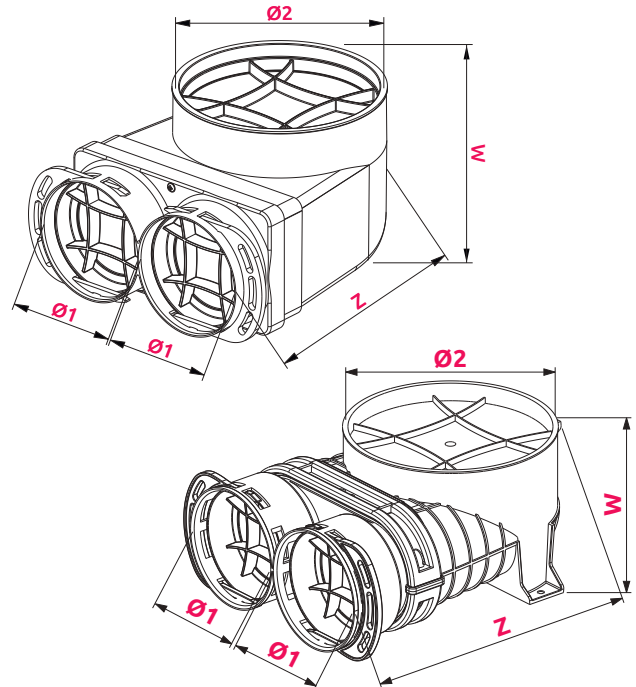

	Ø1	Ø2	Z	W
VPE125-2	75	128	202	110
VPE160-2/90	90	160	278	118

WITH NANOSILVER ADDITIVE
ELIMINATING UP TO 99% BACTERIA



PRODUCT DATA SHEET



TIGHTNESS
CLASS



MATERIAL



BACTERIOSTATIC

Short duct crossover

VMK75-2-S, VMK90-2-S

The VMK AWENTA PRO duct crossover is used for crossing $\varnothing 75$ - $\varnothing 90$ ducts without altering the height of the installation. It also allows ducts to be run over other sanitary or electrical piping and any elements in the path of the duct.

AWENTA PRO crossovers, made of modified polypropylene with the bacteriostatic additive Nano-Silver. Thanks to its robust construction, the crossover can be permanently embedded in the screed or ceiling.

The crossover package includes a set of gaskets and plugs for a tight connection between the socket and the ventilation duct and closure of unused connections.

VMK crossovers are available in two lengths to enable passing from 2 to as many as 8 $\varnothing 75$ - $\varnothing 90$ ventilation ducts.



VMK75-2-S

VMK90-2-S



AIR FLOW CHARACTERISTICS

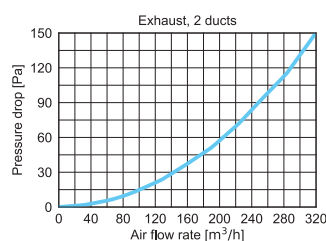
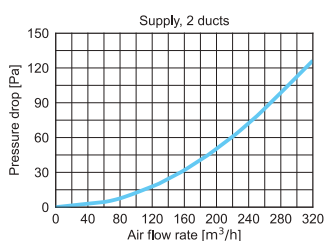
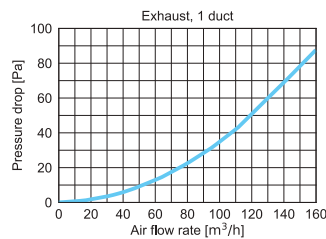
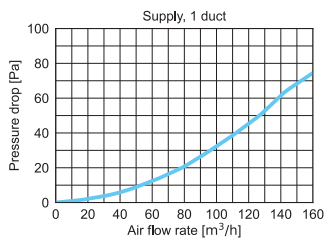
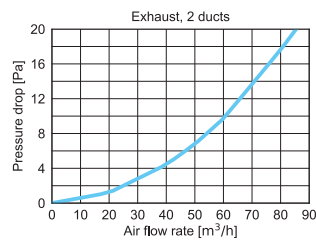
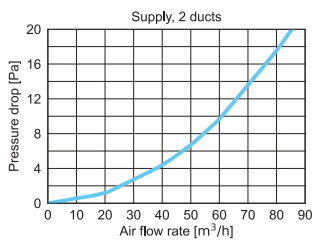
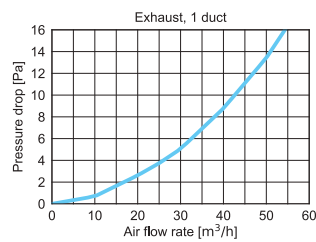
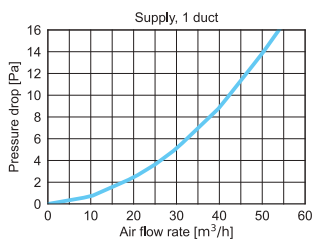

DIMENSIONS

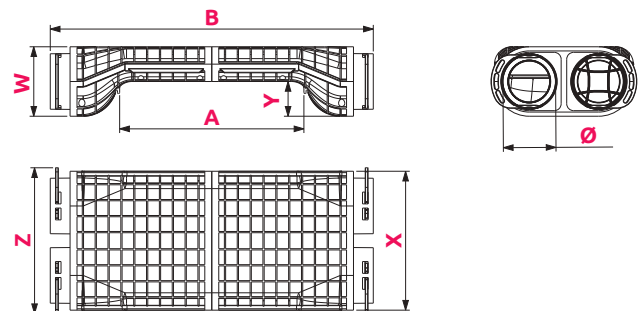

	Ø	W	A	B	Y	Z	X
VMK75-2-S	75	100	265	465	50	210	200
VMK90-2-S	90	100	265	525	50	234	200



WITH **NANOSILVER** ADDITIVE
ELIMINATING UP TO 99% BACTERIA





TIGHTNESS CLASS



MATERIAL



BACTERIOSTATIC

Long duct crossover

VMK75-2-L, VMK90-2-L

The VMK AWENTA PRO duct crossover is used for crossing $\varnothing 75\text{-}\varnothing 90$ ducts without altering the height of the installation. It also allows ducts to be run over other sanitary or electrical piping and any elements in the path of the duct.

AWENTA PRO crossovers, made of modified polypropylene with the bacteriostatic additive Nano-Silver. Thanks to its robust construction, the crossover can be permanently embedded in the screed or ceiling.

The crossover package includes a set of gaskets and plugs for a tight connection between the socket and the ventilation duct and closure of unused connections.

VMK crossovers are available in two lengths to enable passing from 2 to as many as 8 $\varnothing 75\text{-}\varnothing 90$ ventilation ducts.

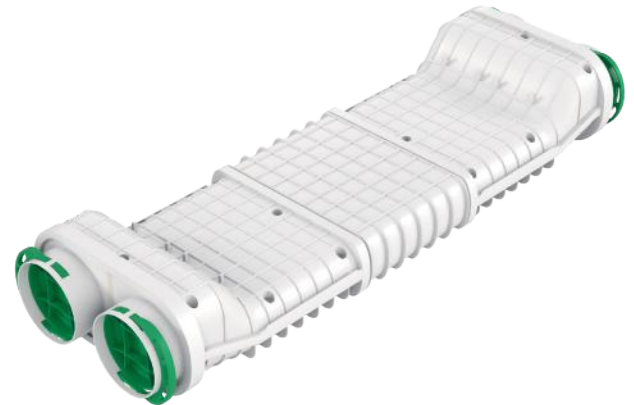

VMK75-2-L

VMK90-2-L



AIR FLOW CHARACTERISTICS

VMK75-2-L

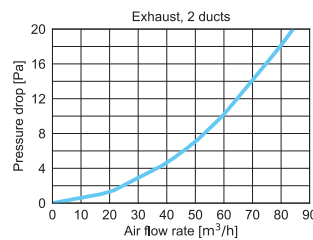
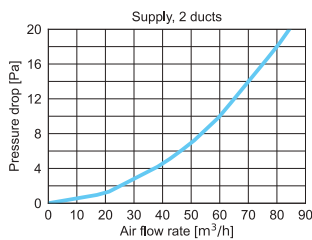
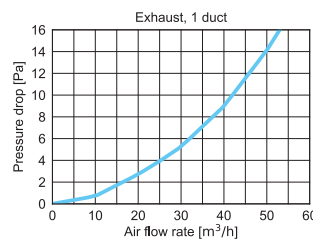
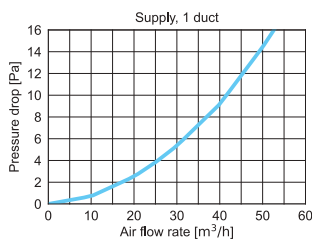

VMK90-2-L

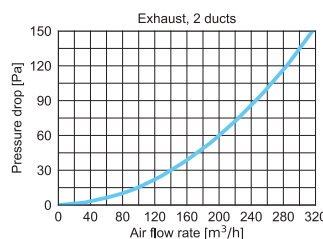
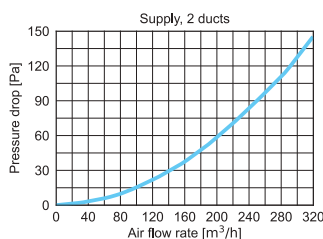
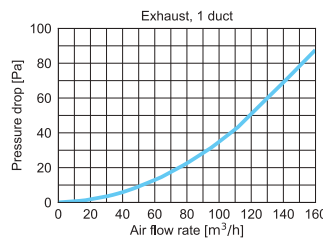
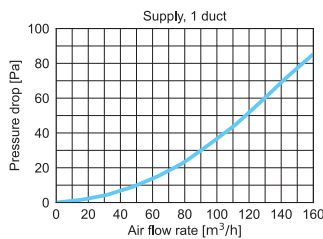

DIMENSIONS

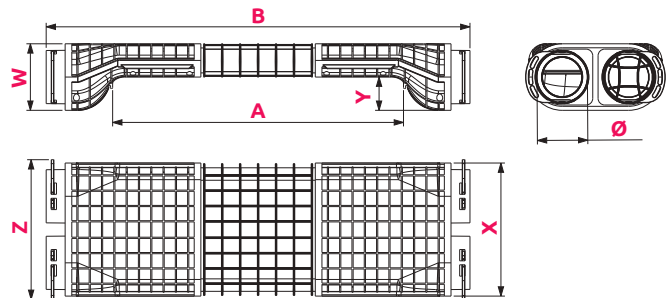

	Ø	W	A	B	Y	Z	X
VMK75-2-L	75	100	437	637	50	210	200
VMK90-2-L	90	100	437	697	50	234	200

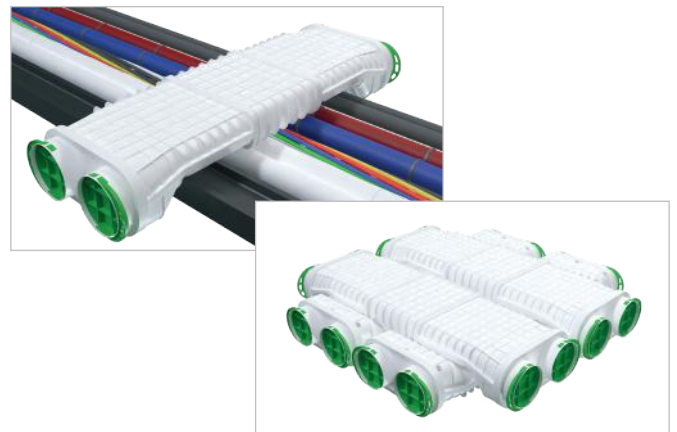

WITH **NANOSILVER** ADDITIVE
ELIMINATING UP TO **99%** BACTERIA

PRODUCT DATA SHEET



TIGHTNESS
CLASS



MATERIAL



BACTERIOSTATIC

Distribution box

VCB160-8, VCB200-8, VCB160-8/90, VCB200-8/90

The AWENTA PRO VCB distribution box is used for the distribution of supplied air or collection of used air from rooms connected to the heat recovery system and it is directly connected to the air handling unit.

AWENTA PRO distribution boxes are made of modified polypropylene with the Nano-Silver bacteriostatic additive. The robust structure is equipped with a system of gaskets guaranteeing tightness and failure-free operation for many years. The use of a bacteriostatic additive made it possible to obtain bacteriostatic activity at a very high level.

The VCB distribution boxes are available in different connection options allowing for the connection of up to 8 Ø75-90 mm ventilation ducts. All VCB boxes are supplied with mounting gaskets for a tight connection between the female connector and the ventilation duct. An integral part of each box is its mounting system, for which special adjustable mounting brackets are used.



VCB160-8

VCB160-8/90

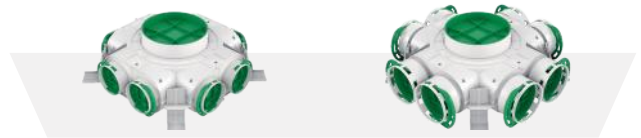

AIR FLOW CHARACTERISTICS

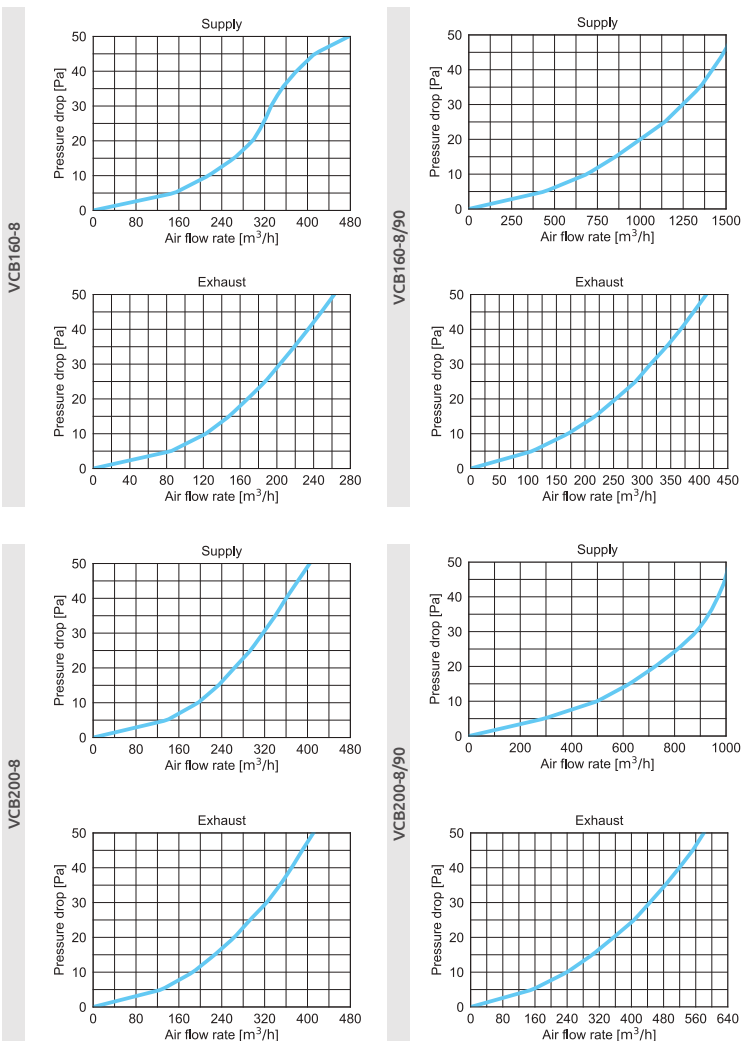

DIMENSIONS

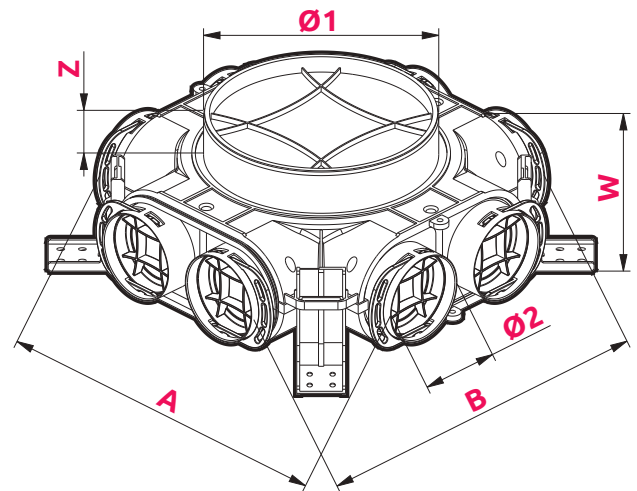

	Ø1	Ø2	A	B	W	Z
VCB160-8	160	75	347	349	104	38
VCB200-8	200	75	347	349	104	38
VCB160-8/90	160	90	407	407	104	38
VCB200-8/90	200	90	407	407	104	38

WITH **NANOSILVER** ADDITIVE
ELIMINATING UP TO 99% BACTERIA





TIGHTNESS CLASS



MATERIAL



BACTERIOSTATIC

Distribution box

VCB160-12, VCB200-12, VCB160-12/90, VCB200-12/90

The Awenta PRO VCB160-12 and VCB200-12 distribution boxes enable the connection of up to 12 Ø75-90 mm ventilation ducts. Ducts not in use can be closed with the supplied end caps.

The box is available in two configurations of connection to the air handling unit: Ø160 mm and Ø200 mm.

The AWENTA PRO distribution boxes are equipped with a patented fixing system that enables precise adjustment of the distance between the box and the mounting planes and makes it easy to remove the box if necessary. Independently adjustable brackets allow the horizontal installation of the unit, enabling it to be tilted as well.

VCB series boxes are designed for installation in a heated area of the building; otherwise, they must be insulated with a layer of mineral wool (min. 15 cm). It can be permanently embedded into the screed or ceiling, or installed under plasterboards.



VCB160-12

VCB160-12/90



AIR FLOW CHARACTERISTICS

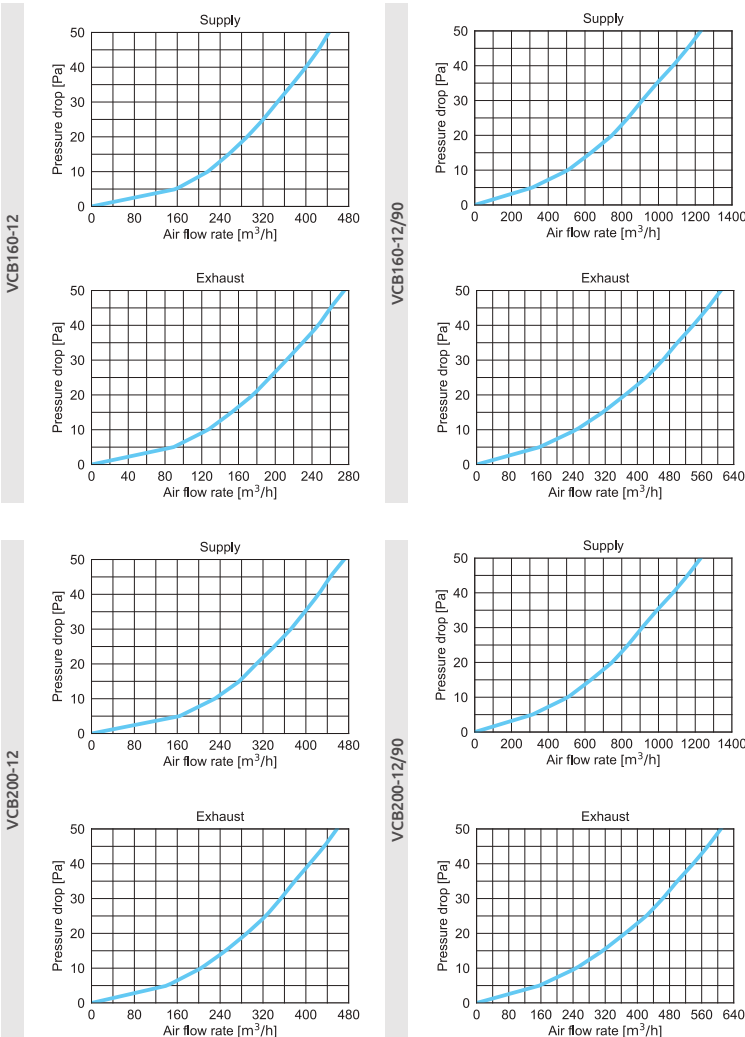

DIMENSIONS

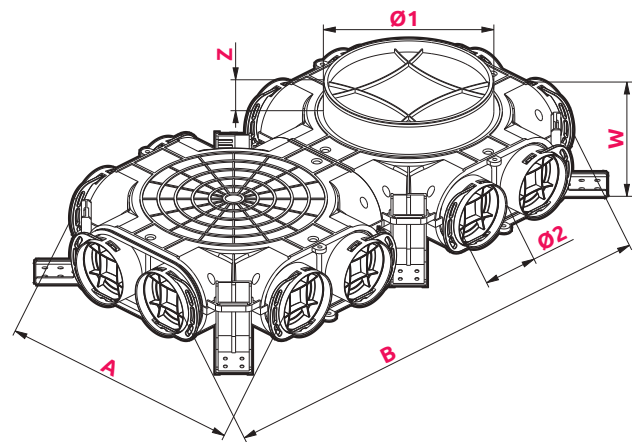

	Ø1	Ø2	A	B	W	Z
VCB160-12	160	75	347	639	104	38
VCB200-12	200	75	347	639	104	38
VCB160-12/90	160	90	407	697	104	38
VCB200-12/90	200	90	407	697	104	38

WITH **NANOSILVER** ADDITIVE
ELIMINATING UP TO **99%** BACTERIA



PRODUCT DATA SHEET

TIGHTNESS
CLASS

MATERIAL



BACTERIOSTATIC

Distribution Box

VCB200-16, VCB200-16/90

The Awenta PRO VCB200-16 distribution box enables the connection of up to 16 Ø75-90 mm ventilation ducts.

Ducts not in use can be closed with the supplied end caps. The box is available with a connector to the air handling unit with a diameter of Ø200 mm.

AWENTA PRO boxes are a well-thought-out design ensuring their use for many years. Thanks to their design and the use of high-quality plastics and bacteriostatic additives, they meet the expectations of the most demanding users. The range of available distribution boxes has been carefully planned to allow for their use in most typical mechanical ventilation systems.



VCB200-16

VCB200-16/90



AIR FLOW CHARACTERISTICS

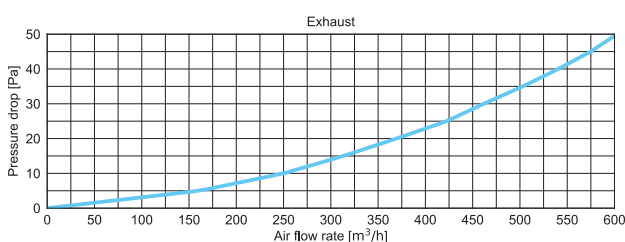
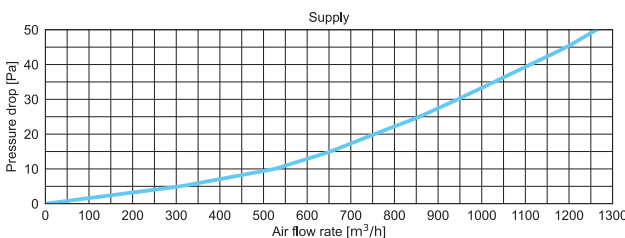
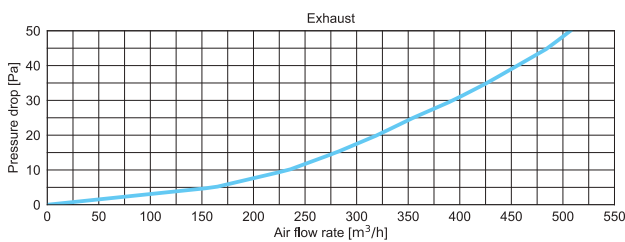
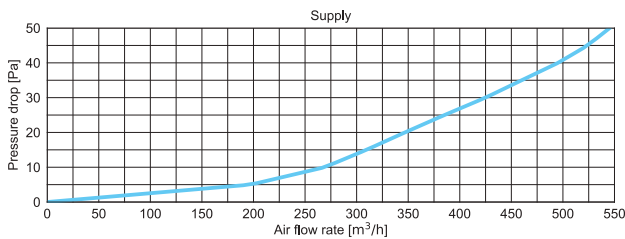

DIMENSIONS

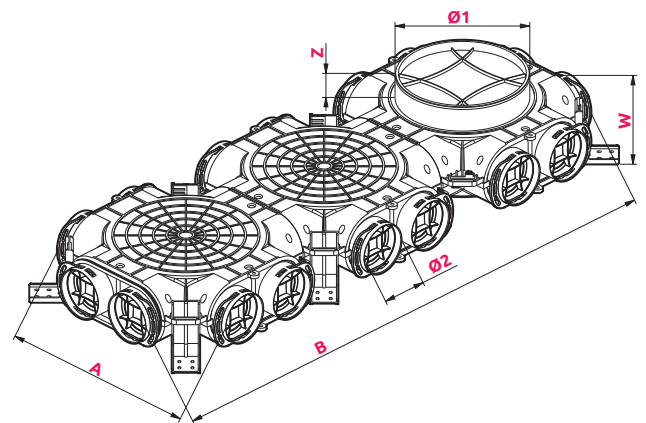

	Ø1	Ø2	A	B	W	Z
VCB200-16	200	75	347	927	104	38
VCB200-16/90	200	90	407	988	104	38

WITH **NANOSILVER** ADDITIVE
ELIMINATING UP TO 99% BACTERIA



PRODUCT DATA SHEET

Corner distribution box

VCBR160-8-L, VCBR160-8/90-L, VCBR200-8-L, VCBR200-8/90-L
 VCBR160-8-P, VCBR160-8/90-P, VCBR200-8-P, VCBR200-8/90-P

NOVELTY

ATC1
TIGHTNESS CLASS

PP
MATERIAL

BACTERIOSTATIC

The Awenta PRO corner distribution box allows you to connect up to 8 ventilation channels with a diameter of 75-90 mm.

Unused connections can be closed with the plugs included in the set. Two versions of the connection to the control unit are available, with diameters of Ø160 mm and Ø200 mm, as well as left and right variants to facilitate adaptation to the installation layout.

AWENTA PRO boxes are a well-thought-out design created with many years of reliable use in mind. Thanks to their solid housing, the use of high-quality plastics and bacteriostatic additives, the boxes meet the requirements of even the most demanding users. The wide range of available models has been carefully developed to allow their use in most standard mechanical ventilation installations.



VCBR160-8-L

VCBR200-8-P/90



AIR FLOW CHARACTERISTICS

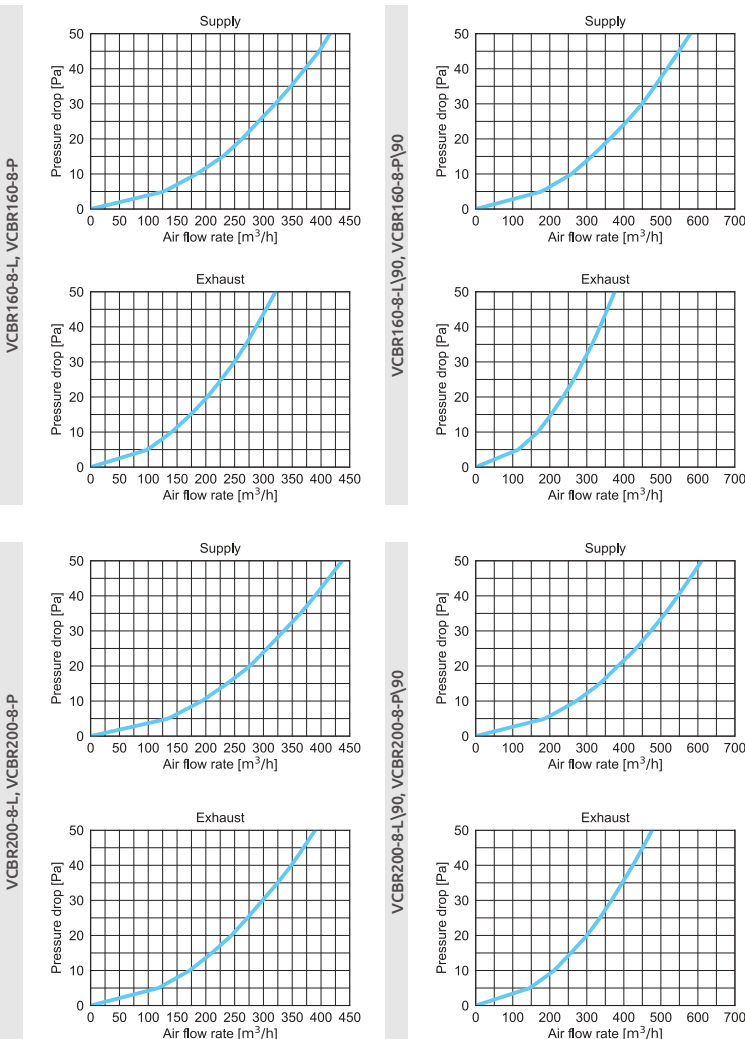

DIMENSIONS

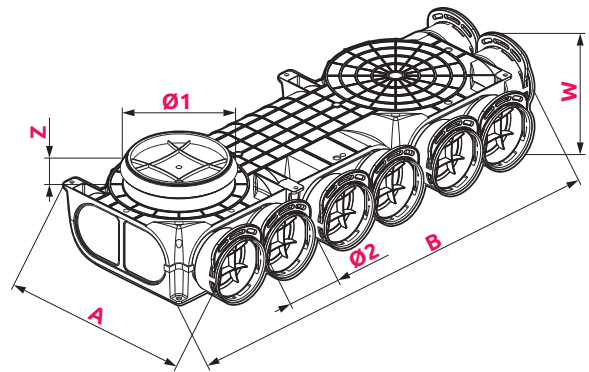

	Ø1	Ø2	A	B	W	Z
VCBR160-8-L	160	75	283	727	107	38
VCBR200-8-L	200	75	283	727	107	38
VCBR160-8-P	160	75	283	727	107	38
VCBR200-8-P	200	75	283	727	107	38
VCBR160-8-L/90	160	90	298	742	119	38
VCBR200-8-L/90	200	90	298	742	119	38
VCBR160-8-P/90	160	90	298	742	119	38
VCBR200-8-P/90	200	90	298	742	119	38

WITH NANOSILVER ADDITIVE
 ELIMINATING UP TO 99% BACTERIA

Heat recovery system components

PRODUCT DATA SHEET

Distribution box
with side connector

VCB125-6, VCB160-6, VCB160-6/90

TIGHTNESS
CLASS

MATERIAL



BACTERIOSTATIC

The Awenta PRO distribution box allows for the connection of up to 6 Ø75-90 ventilation ducts.

As with the other distribution boxes in the VCB series, unused spigots can be covered with plugs with gaskets included with the product. The box is characterised by a side connection available in two variants with a diameter of Ø160 mm and Ø125 mm.

Distribution boxes with side connections are ideal for installation above suspended ceilings and wherever installation height is limited.

The suitably profiled shape of the Awenta PRO boxes allows for a quiet air flow, while ensuring low pressure loss.

AWENTA PRO boxes are a well-thought-out design for long-term use. Thanks to their structure and the use of high-quality plastics and bacteriostatic additives, they will meet the expectations of the most demanding users.



VCB125-6

VCB160-6

VCB160-6/90



AIR FLOW CHARACTERISTICS

VCB125-6

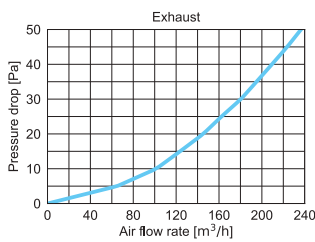
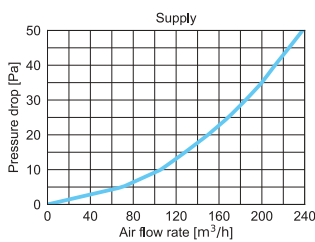

VCB160-6

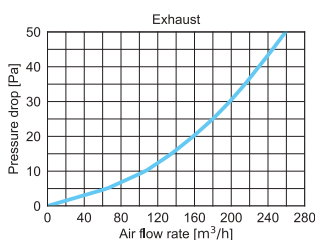
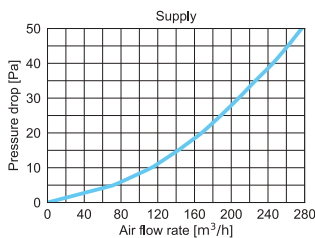

VCB160-6/90

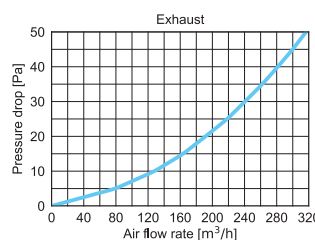
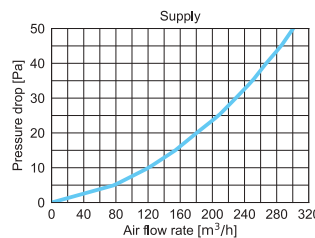

DIMENSIONS

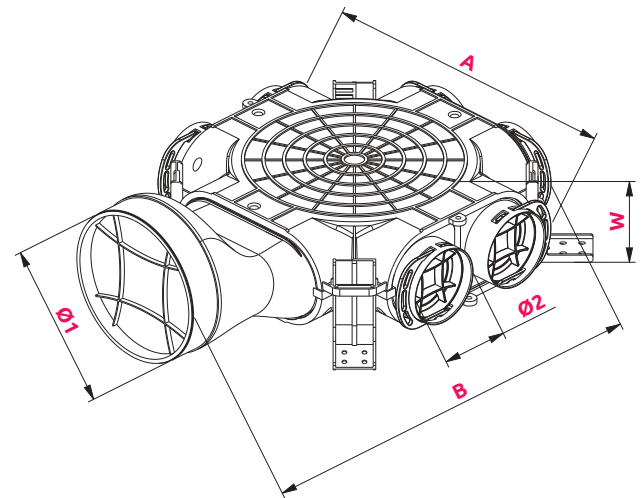

	Ø1	Ø2	A	B	W
VCB125-6	125	75	347	445	104
VCB160-6	160	75	347	475	104
VCB160-6/90	160	90	407	505	104

WITH **NANOSILVER** ADDITIVE
ELIMINATING UP TO 99% BACTERIA



PRODUCT DATA SHEET

Distribution box with side connector

VCB160-10, VCB160-10/90



The Awenta PRO distribution box allows the connection of up to 10 Ø75-90 ventilation ducts.

As with the other distribution boxes in the VCB series, unused spigots can be covered with plugs with gaskets included with the product. The box is characterised by a side connection with a diameter of Ø160 mm.

Distribution boxes with side connections are ideal for installation above suspended ceilings and wherever installation height is limited.

The suitably profiled shape of the Awenta PRO boxes allows for a quiet air flow, while ensuring low pressure loss.

The range of distribution boxes available has been carefully planned to allow their use in most typical mechanical ventilation systems.



VCB160-10

VCB160-10/90



AIR FLOW CHARACTERISTICS

VCB160-10

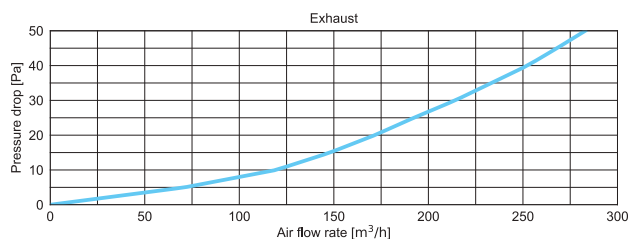
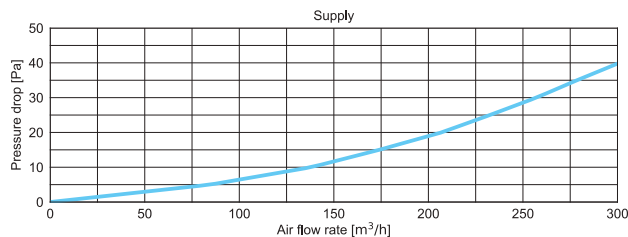

VCB160-10/90

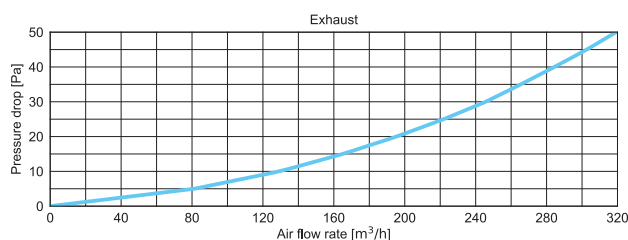
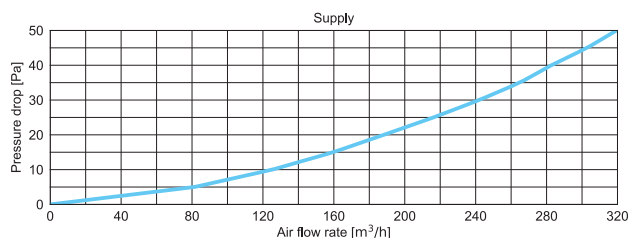

DIMENSIONS

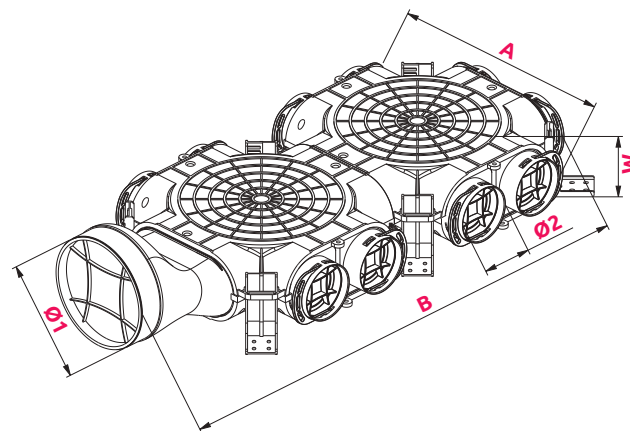

	Ø1	Ø2	A	B	W
VCB160-10	160	75	347	766	104
VCB160-10/90	160	90	407	795	104

WITH **NANOSILVER** ADDITIVE
ELIMINATING UP TO 99% BACTERIA



PRODUCT DATA SHEET

Distribution box with side connector

VCB160-14, VCB160-14/90



The Awenta PRO VCB distribution box allows the connection of up to 14 Ø75-90 ventilation ducts.

As with the other distribution boxes in the VCB series, unused spigots can be covered with plugs with gaskets included with the product. The box is characterised by a side connection with a diameter of Ø160 mm.

Distribution boxes with side connections are ideal for installation above suspended ceilings and wherever installation height is limited.

The suitably profiled shape of the Awenta PRO boxes allows for a quiet air flow, while ensuring low pressure loss.

AWENTA PRO boxes are a well-thought-out design for long-term use. Thanks to their structure and the use of high-quality plastics and bacteriostatic additives, they will meet the expectations of the most demanding users.



VCB160-14

VCB160-14/90



AIR FLOW CHARACTERISTICS

VCB160-14

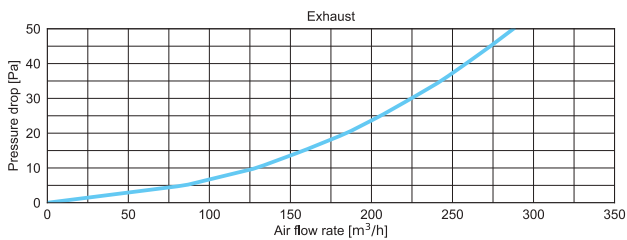
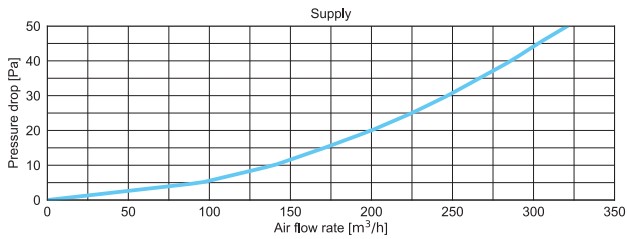

VCB160-14/90

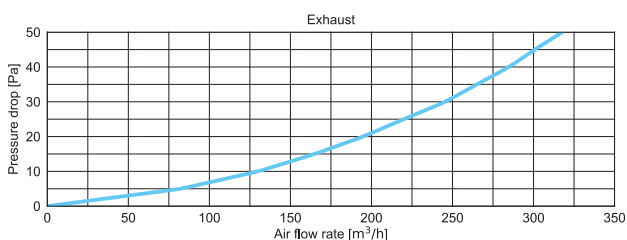
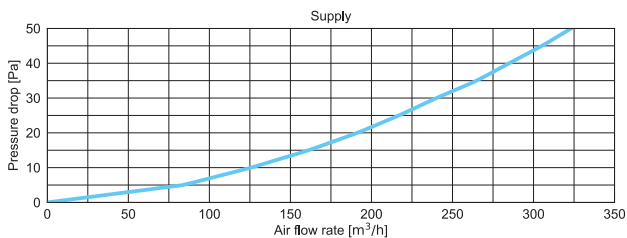

DIMENSIONS

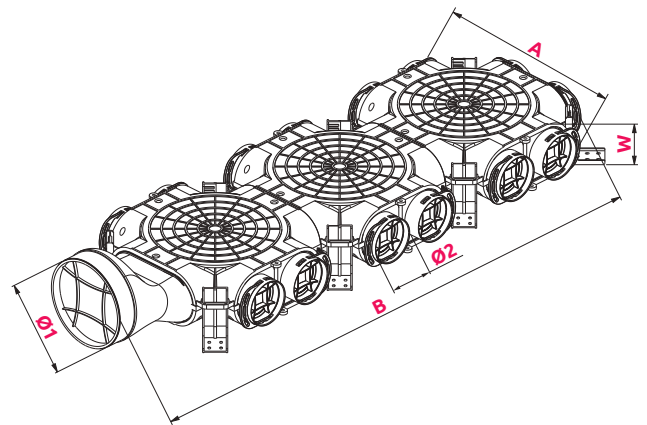

	Ø1	Ø2	A	B	W
VCB160-14	160	75	347	1057	104
VCB160-14/90	160	90	407	1086	104

WITH **NANOSILVER** ADDITIVE
ELIMINATING UP TO 99% BACTERIA



PRODUCT DATA SHEET



TIGHTNESS CLASS



MATERIAL



BACTERIOSTATIC

Straight-through distribution box

VCB160/200-8, VCB160/200-12, VCB160/200-16,
VCB160/200-8/90, VCB160/200-12/90, VCB160/200-16

The Awenta PRO VCB straight-through distribution box is designed to distribute the air stream between two floors. Straight-through ducts, Ø160 or Ø200 mm, are used for air flow to the next floor of the building, while Ø75-90 mm ducts enable connection of from 8 up to 16 ducts for ventilation of rooms on the lower floor. The air flow between floors is adjusted by means of air valves.

In addition, the user can install a damper upstream of the inlet to the distribution box on the upper floor. Ducts not in use can be closed with the supplied end caps with gaskets.

The AWENTA PRO distribution boxes are equipped with a patented fixing system that enables precise adjustment of the distance between the box and the mounting planes and makes it easy to remove the box if necessary. Independently adjustable brackets allow the horizontal installation of the unit, enabling it to be tilted as well.

VCB series boxes are designed for installation in a heated area of the building; otherwise, they must be insulated with a layer of mineral wool (min. 15 cm). It can be permanently embedded into the screed or ceiling, or installed under plasterboards.

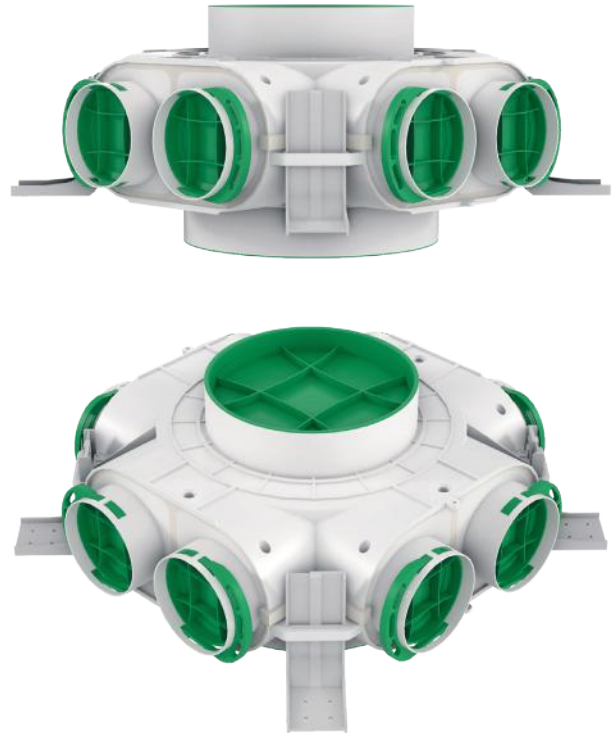

DIMENSIONS

	Ø1	Ø2	Ø3	A	B	W	Z
VCB160/200-8	160	75	200	347	349	104	38
VCB160/200-8/90	160	90	200	407	407	104	38
VCB160/200-12	160	75	200	347	639	104	38
VCB160/200-12/90	160	90	200	407	697	104	38
VCB160/200-16	160	75	200	347	927	104	38
VCB160/200-16/90	160	90	200	407	988	104	38

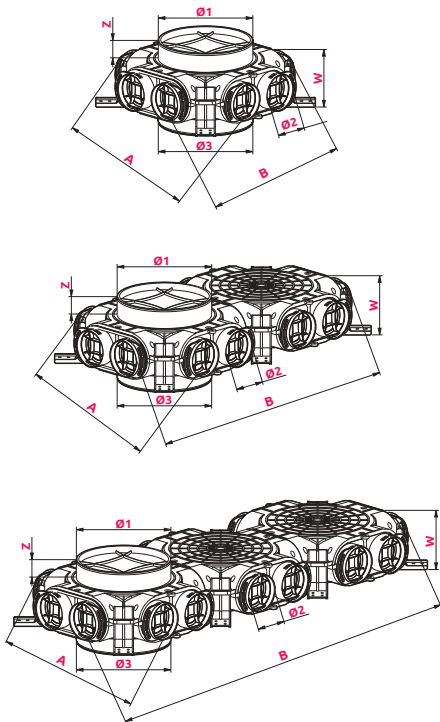

VCB160/200-8



VCB160/200-8/90



VCB160/200-12



VCB160/200-12/90



VCB160/200-16



VCB160/200-16/90



WITH **NANOSILVER** ADDITIVE
ELIMINATING UP TO 99% BACTERIA



PRODUCT DATA SHEET

NOVELTY

TIGHTNESS
CLASS

MATERIAL



BACTERIOSTATIC

Straight-through distribution box Corner

VCBR160/200-8-L, VCBR160/200-8-P, VCBR160/200-8-L/90, VCBR160/200-8-P/90

The Awenta PRO through-duct distribution box is designed to distribute air flow between two floors. The $\varnothing 160 / \varnothing 200$ mm through duct is used for air flow to the next floor of the building, while the $\varnothing 75-90$ mm ducts allow connection to up to 8 ventilation ducts on the lower floor. The box is available in left and right versions to facilitate adaptation to the installation layout. The air flow between floors is regulated by anemostats. Additionally, a damper can be installed in front of the inlet to the distribution box on the upper floor. Unused connections can be closed with the plugs included in the set.

VCBR series boxes are designed for installation in a heated area of the building, otherwise they must be insulated with a layer of mineral wool (min. 15 cm). They can be permanently embedded in screed or ceiling or built in under plasterboard.



VCBR160/200-8-L

VCBR160/200-8-P/90



	$\varnothing 1$	$\varnothing 2$	$\varnothing 3$	A	B	W	Z
VCBR160/200-8-L	160	200	75	283	727	107	38
VCBR160/200-8-P	160	200	75	283	727	107	38
VCBR160/200-8-L/90	160	200	90	298	742	119	38
VCBR160/200-8-P/90	160	200	90	298	742	119	38

DIMENSIONS

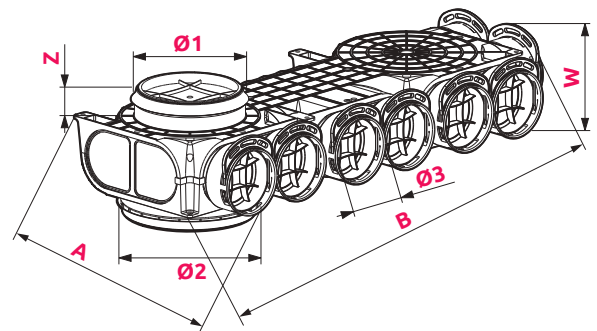

WITH **NANOSILVER** ADDITIVE
ELIMINATING UP TO 99% BACTERIA



Directional diffuser

VAK125, VAK125CZ, VAK160, VAK160CZ

The directional diffuser is the termination of the ventilation system. The product is equipped with a special damper that allows the setting of the direction of the air supply. This solution is used in situations where the diffuser is installed close to walls or fixtures that may be adversely affected by the air supply.

The intensity of the supply air flow is adjusted by means of a rotary disc.



VAK*/WHITE

VAK*CZ/BLACK

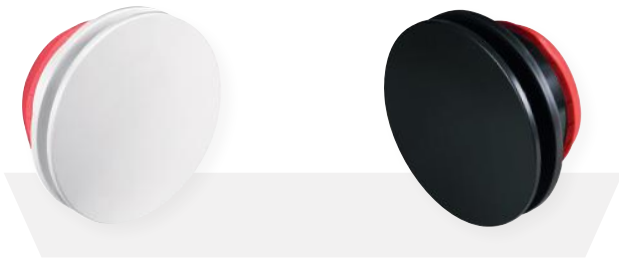

AIR FLOW CHARACTERISTICS

DIMENSIONS

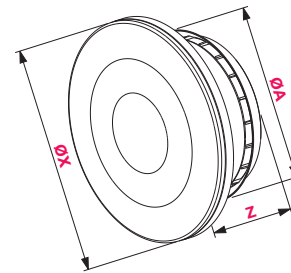
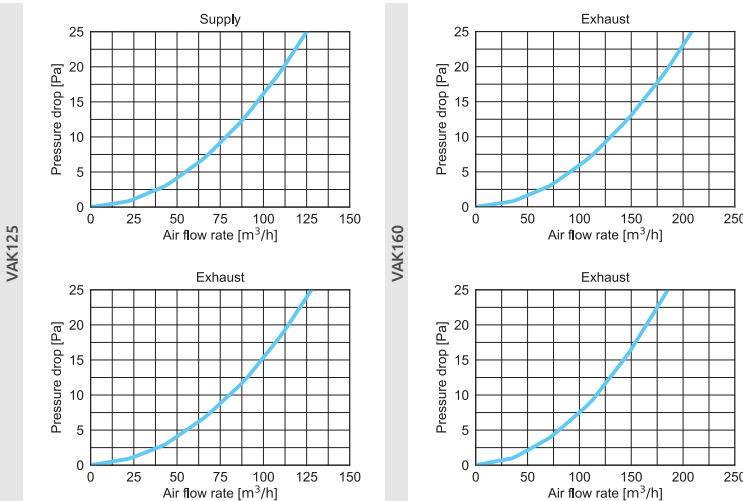

	ØX	ØA	Z
VAK125	173	125	54
VAK125CZ	173	125	54
NOVELTY VAK160	208	160	54
NOVELTY VAK160CZ	208	160	54

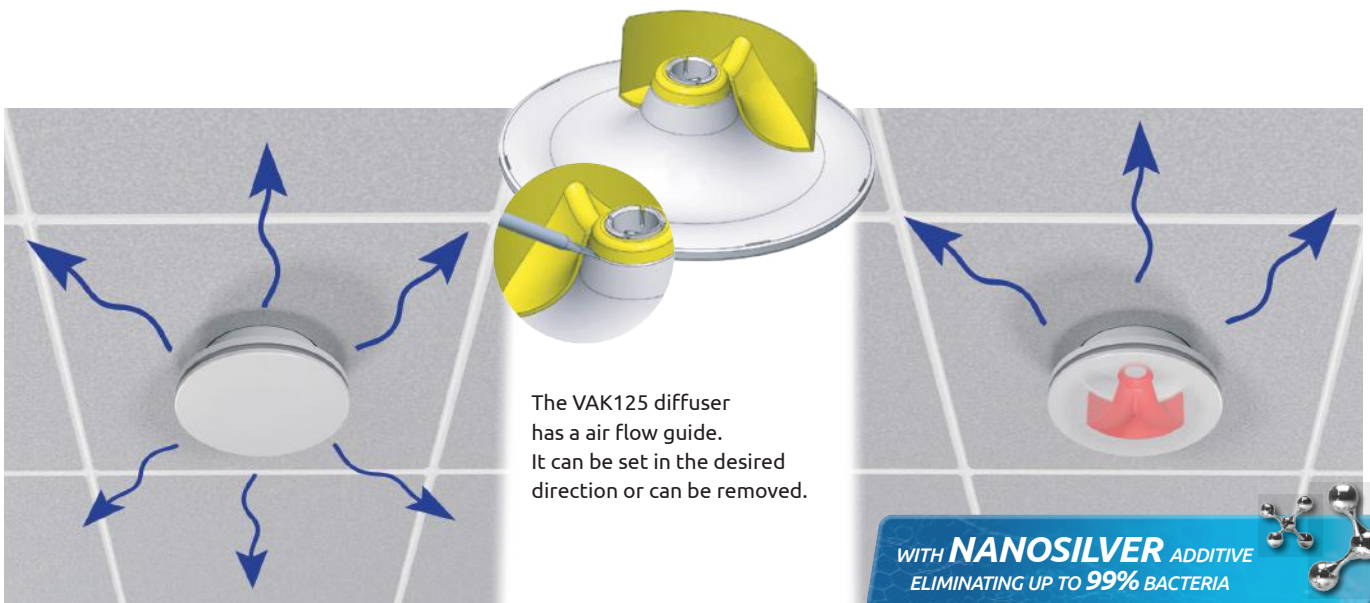

The VAK125 diffuser has a air flow guide. It can be set in the desired direction or can be removed.

WITH **NANOSILVER** ADDITIVE
ELIMINATING UP TO **99%** BACTERIA

PRODUCT DATA SHEET



MATERIAL



BACTERIOSTATIC

Panel diffuser

VAP125, VAP125CZ

The VAP125 diffuser is fitted with a front panel that can be assembled and removed without tools. This solution makes it easier to keep the product clean.

It is a twin solution to the SYSTEM+ product range offered by AWENTA, which allows the use of plastic panels for Ø125 fans.

Beneath the aesthetic front panel, there is a damper that, similar to other air diffusers, allows for smooth airflow regulation.



VAP125/WHITE



VAP125CZ/BLACK

AIR FLOW CHARACTERISTICS

VAP 125

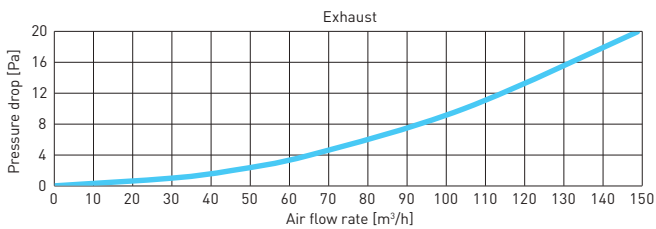
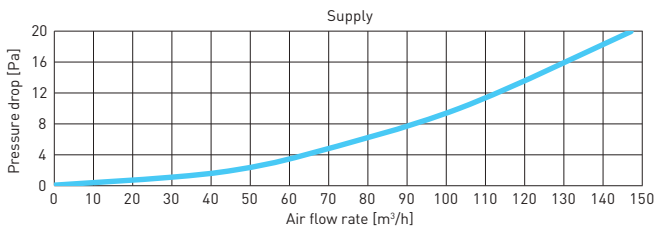

DIMENSIONS

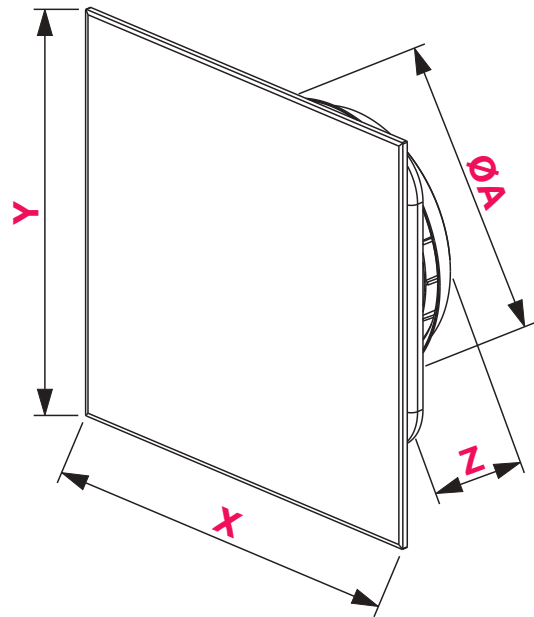

	X	Y	Z	ØA
VAP125	200	200	36	125
VAP125CZ	200	200	36	125

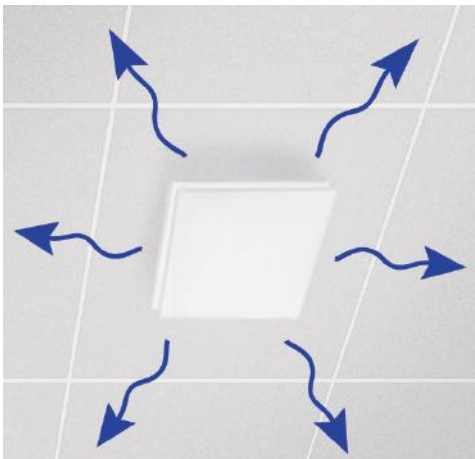

WITH **NANOSILVER** ADDITIVE
ELIMINATING UP TO 99% BACTERIA





MATERIAL



BACTERIOSTATIC

Panel diffuser

VAPO125, VAPO125CZ

The VAPO125 diffuser is fitted with a front panel that can be assembled and removed without tools. This solution makes it easier to keep the product clean.

It is a twin solution to the SYSTEM+ product range offered by AWENTA, which allows the use of plastic panels for Ø125 fans.

Beneath the aesthetic front panel, there is a damper that, similar to other air diffusers, allows for smooth airflow regulation.



VAPO125/WHITE

VAPO125CZ/BLACK

AIR FLOW CHARACTERISTICS

VAPO 125

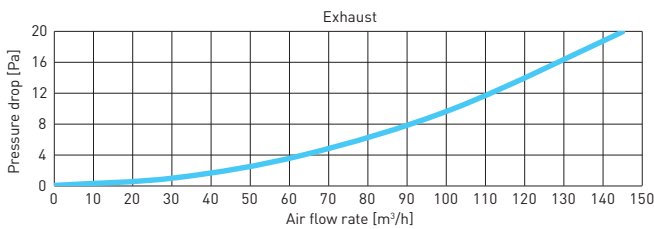
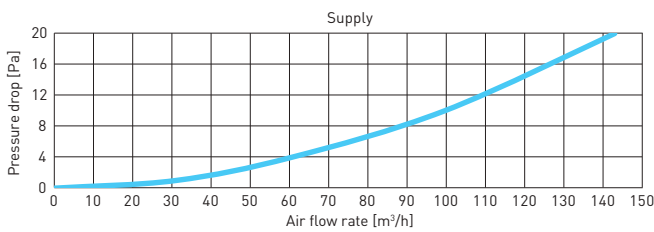

DIMENSIONS

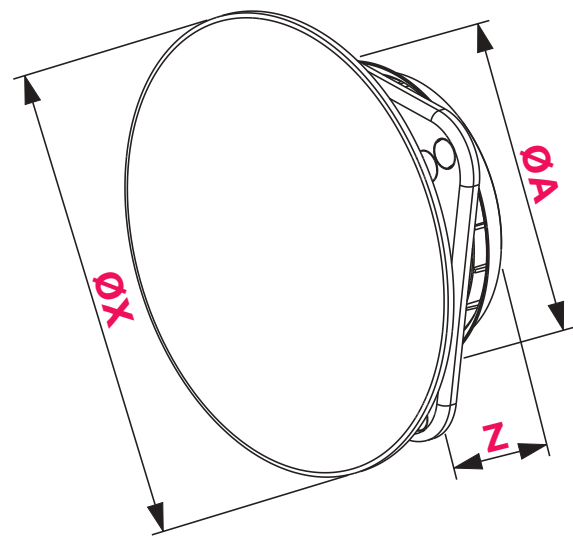

	ØX	ØA	Z
VAPO125	200	125	36
VAPO125CZ	200	125	36

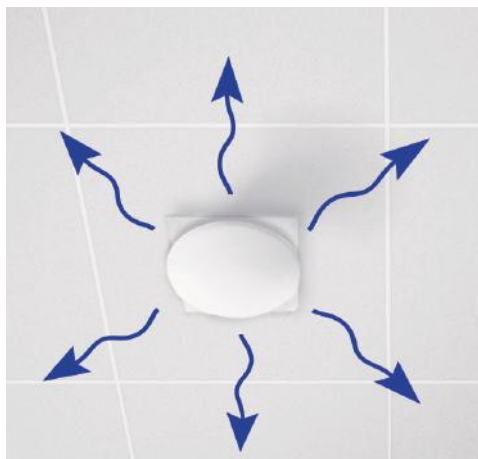

WITH **NANOSILVER** ADDITIVE
ELIMINATING UP TO **99%** BACTERIA

Intake grilles

VCSM

The initial component of ventilation systems with heat recovery unit. Designed for external use in residential and public buildings. Equipped with a drip deflector to protect the wall from water droplets and a protective mesh to cover the inlet opening.

The designed geometry ensures minimal air resistance/pressure drop while providing protection against rainwater.

A rubber gasket facilitates installation and prevents water leakage from the ventilation duct. Mounting holes at the corners allow for attachment to the wall. The side placement of detachable intake front screws makes installation and disassembly for maintenance easier.

CHARACTERISTICS OF COLOUR VARIATIONS

White, Graphite(GR)

All materials used are suitable for external applications

- Galvanized steel sheet with a thickness of 0.7 mm, powder-coated using passivation technology for additional corrosion protection
- An attractive color used in contemporary construction

Inox(I)

- High-quality stainless steel sheet - acid-resistant, chrome-nickel (grade: 316L/1.4404) with a thickness of 0.6 mm
- Aesthetically polished surface

Protective mesh for the inlet opening

Mounting gasket with double-lipped seal

Fast and easy installation (4 mounting holes in the corners)

AIR FLOW CHARACTERISTICS

VCSM 100

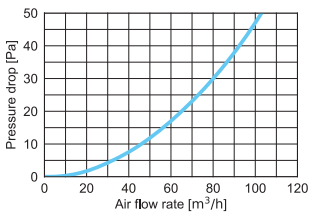

VCSM 125

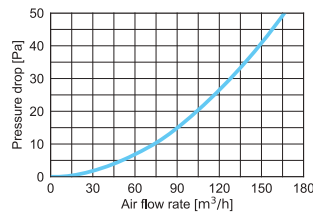

VCSM 150

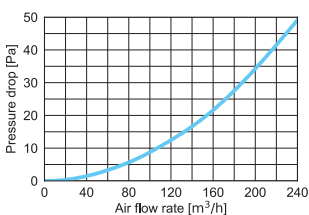

VCSM 160

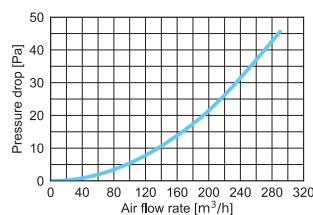

VCSM 180

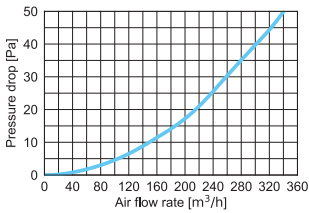

VCSM 200

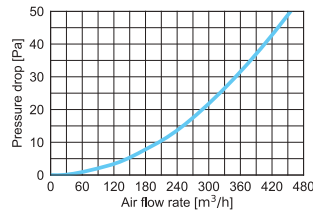

VCSM 250

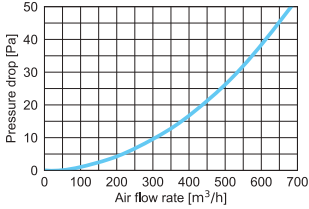

VCSM 315

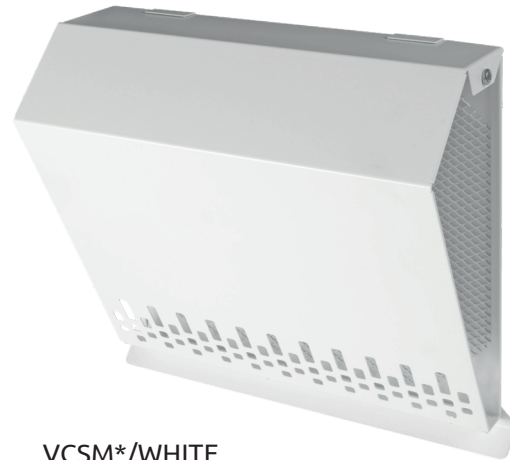
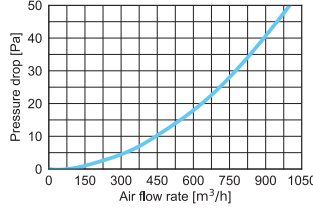

VCSM*/WHITE



VCSM*GR/GRAPHITE



VCSM*/INOX

* Connector diameter

DIMENSIONS

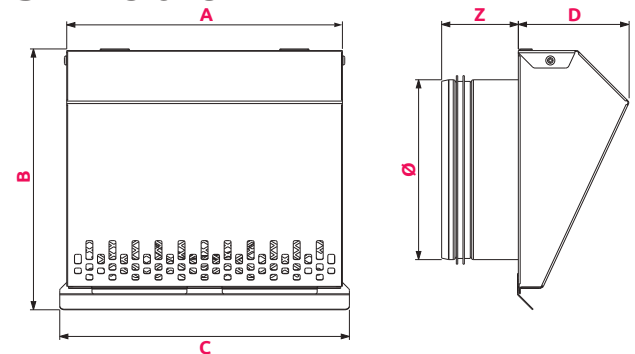

	Ø	A	B	C	D	Z
VCSM100	100	177	162	180	63	56
VCSM125	125	202	190	210	78	61
VCSM150	150	227	215	239	92	66
VCSM160	160	237	224	249	95	66
VCSM180	180	257	245	269	101	66
VCSM200	200	277	264	289	108	66
VCSM250	250	327	314	339	124	66
VCSM315	315	392	379	404	144	76

MOUNTING POSITION

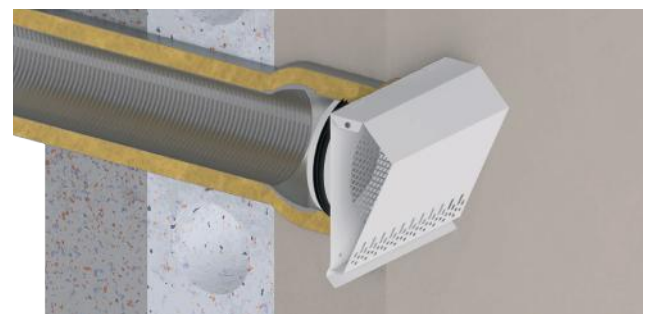

Exhaust grilles

VWSM

Endings of ducts in mechanical ventilation systems with heat recovery unit. Designed for external use in residential and public buildings. Equipped with a drip deflector to protect the wall from water droplets and a protective mesh to cover the outlet opening.

The perpendicular geometry of the air discharge with side closure prevents the wall from getting dirty due to exhausted air. The designed geometry ensures minimal resistance/pressure drop of the expelled air.

A rubber gasket facilitates installation and prevents water from flowing out of the ventilation duct. Mounting holes in the corners allow for attachment to the wall. The side positioning of the detachable outlet front screws facilitates installation and disassembly for maintenance easier.

CHARACTERISTICS OF COLOUR VARIATIONS

White, Graphite(GR)	Inox(I)
All materials used are suitable for external applications	
<ul style="list-style-type: none"> Galvanized steel sheet with a thickness of 0.7 mm, powder-coated using passivation technology for additional corrosion protection An attractive color used in contemporary construction 	<ul style="list-style-type: none"> High-quality stainless steel sheet - acid-resistant, chrome-nickel (grade: 316L/1.4404) with a thickness of 0.5 - 0.6 mm Aesthetically polished surface
Protective mesh for the outlet opening	
Mounting gasket with double-lipped seal	
Fast and easy installation (4 mounting holes in the corners)	



VWSM*/WHITE



VWSM*GR/GRAPHITE



VWSM*I/INOX

* Connector diameter

DIMENSIONS

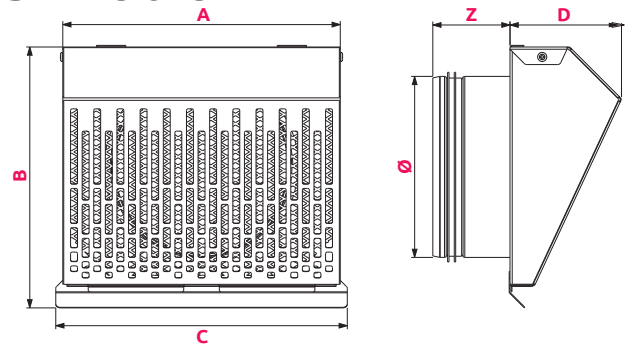

	Ø	A	B	C	D	Z
VWSM100	100	177	162	180	63	56
VWSM125	125	202	190	210	78	61
VWSM150	150	227	215	239	92	66
VWSM160	160	237	224	249	95	66
VWSM180	180	257	245	269	101	66
VWSM200	200	277	264	289	108	66
VWSM250	250	327	314	339	124	66
VWSM315	315	392	379	404	144	76

MOUNTING POSITION



AIR FLOW CHARACTERISTICS

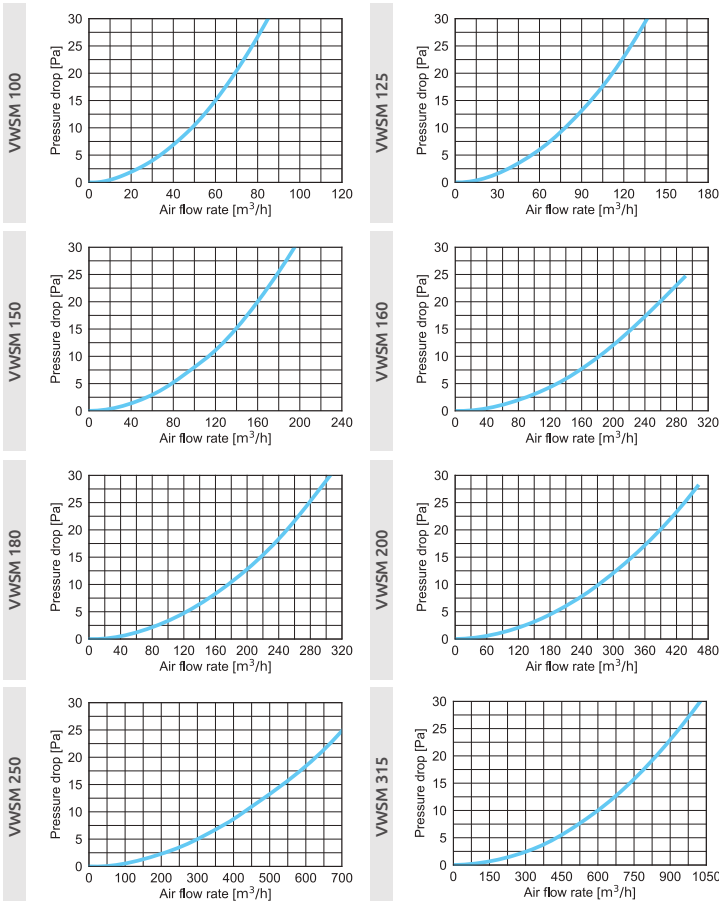

PRODUCT DATA SHEET

Ventilation duct

VFG75, VFB75, VFG90, VFB90



MATERIAL



BACTERIOSTATIC

The VFG ducts are used to transport air in mechanical ventilation systems. They are characterised by very high flexibility, which allows for free shaping of their course, bending and adjustment to the installation conditions, without the need of using additional connectors and fittings. The duct design provides a mechanical compressive strength of more than 450 N, which allows them to be poured over with structural concrete.

The double-walled duct design with partially closed air voids suppresses the noise caused by air flowing inside the duct and provides thermal insulation. The VFG75 ducts have an antibacterial internal coating containing silver in the amount of 150 ppm in the polymer matrix so it does not migrate, ionise or elute. The use of silver ensures a long-lasting bactericidal effect regardless of the air temperature and humidity and prevents bacteria from developing defence mechanisms.

The inner layer also has an antistatic effect, which reduces the settling and accumulation of dust in the ducts. A smooth inner surface allows for high air flows with low-pressure losses contributing to the low energy intensity of the entire system. It also makes it easier to clean the ducts if needed.

The ergonomically shaped VNK cutter with a replaceable blade is used for cutting ducts.



duct characteristics	VFG75, VFG90	VFB75, VFB90
compression strength	(PN-EN 61386-241):450 N	
impact resistance	(PN-EN 61386-241): Normal (N)	
bending strength	flexible	
flammability	yes	
antibacterial effect after 24h	61-92%	none
outer layer – material	modified polyethylene (HDPE-mod)	
outer layer – colour	transparent	
inner layer – material	modified polyethylene (mod-LDPE), antistatic, antibacterial layer – silver 150 ppm	modified polyethylene (mod-LDPE)
inner layer – colour	green	blue
unit packaging	50 lm	

AIR FLOW CHARACTERISTICS

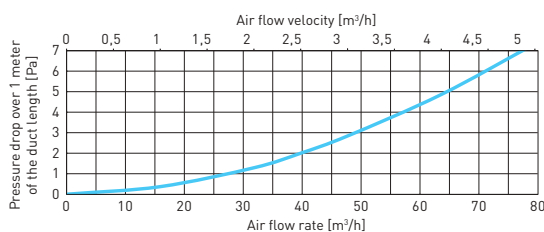
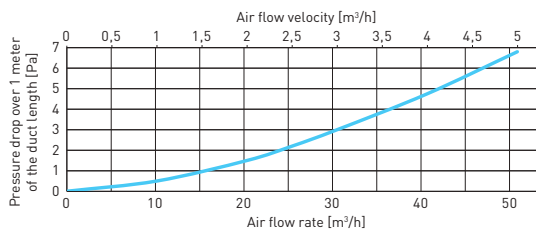

Air flow velocity	VFB/VFG 75			VFB/VFG 90		
	2 [m/s]	2,5 [m/s]	3 [m/s]	2 [m/s]	2,5 [m/s]	3 [m/s]
Air flow rate [m³/h] – 1 duct	20,4	25,5	30,5	31,8	39,8	47,7
Air flow rate [m³/h] – 2 ducts	40,7	50,9	61,1	63,6	79,6	95,4
Air flow rate [m³/h] – 3 ducts	61,1	76,4	91,6	95,4	119,4	143,1

Duct length	Pressure drop [Pa]			Pressure drop [Pa]		
	2 [m/s]	2,5 [m/s]	3 [m/s]	2 [m/s]	2,5 [m/s]	3 [m/s]
1 lm	1,5	2,2	3,0	1,3	2	2,8
2 lm	3,0	3,5	6,0	2,6	3,5	5,7
4 lm	6,0	8,8	12,0	5,2	8	11,4
6 lm	9,0	13,2	18,0	7,7	12	17
8 lm	12,0	17,6	24,0	10,3	16	22,7
10 lm	15,0	22,0	30,0	12,9	20	28,4
12 lm	18,0	26,4	36,0	15,5	24	34,1
14 lm	21,0	30,8	42,0	18,1	28	39,8
16 lm	24,0	35,2	48,0	20,6	32	45,4
18 lm	27,0	39,6	54,0	23,2	36	51,1
20 lm	30,0	44,0	60,0	25,8	40	56,8

Nominal dimension DN (mm)	Inner diameter (mm)	Outer diameter (mm)	Minimum bending radius (above 100°C) (m)	Lengths of sections (m)
75	61	76,2	0,17	50
90	76	91,2	0,17	50

Circular duct Ø125 for the plenum box

KO125-05, KO125-10, KO125-15, KO125-065

The circular duct allows for extending the connector in the plenum boxes to the required length and install the air valve (supply or exhaust) in the subsidence of the suspended ceiling or the under ceiling.

Available in 50 cm, 100 cm and 150 cm sections, made of PVC.

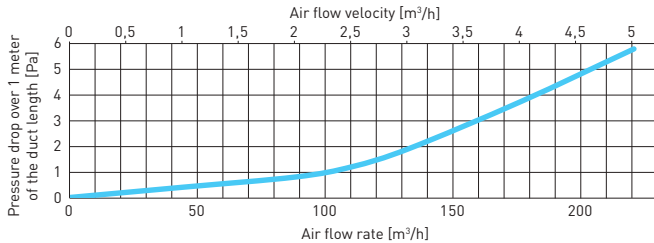

Air flow velocity	2 [m/s]	2,5 [m/s]	3 [m/s]
Duct length	Pressure drop [Pa]		
1 lm	0,8	1,2	2,0
2 lm	1,6	3,5	4,0
4 lm	3,2	4,8	8,0
6 lm	4,8	7,2	12,0
8 lm	6,4	9,6	16,0
10 lm	8,0	12,0	20,0
12 lm	9,6	14,4	24,0
14 lm	11,2	16,8	28,0
16 lm	12,8	19,2	32,0
18 lm	14,4	21,6	36,0
20 lm	16,0	24,0	40,0

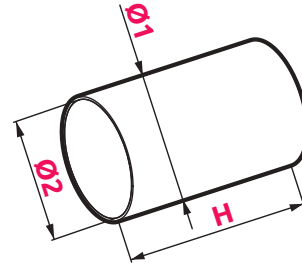

INDEX	Ø	Ø1	Ø2	H
KO125-05	Ø125	128	125	500
KO125-10	Ø125	128	125	1000
KO125-15	Ø125	128	125	1500
KO125-065	Ø125	128	125	650

Circular duct Ø160 for the distribution box

KO160-05, KO160-10, KO160-15

Ventilation ducts Ø160 mm are made of PVC in three lengths: 50 cm, 100 cm and 150 cm.

They are designed for the installation of distribution boxes.

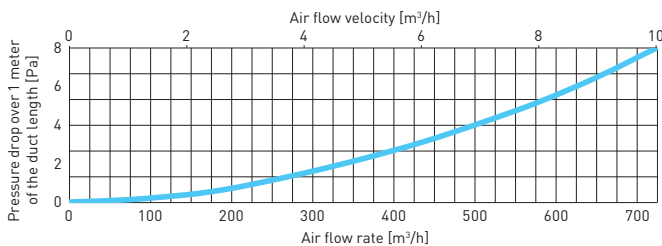

Air flow velocity	2 [m/s]	2,5 [m/s]	3 [m/s]
Duct length	Pressure drop [Pa]		
1 lm	0,4	0,6	0,9
2 lm	0,8	1,2	1,7
4 lm	1,5	2,3	3,4
6 lm	2,3	3,5	5,1
8 lm	3,0	4,6	6,8
10 lm	3,8	5,8	8,5
12 lm	4,6	7,0	10,2
14 lm	5,3	8,1	11,9
16 lm	6,1	9,3	13,6
18 lm	6,8	10,4	15,3
20 lm	7,6	11,6	17,0

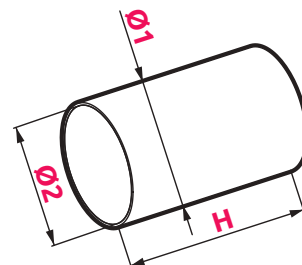

INDEX	Ø	Ø1	Ø2	H
KO160-05	Ø160	163	160	500
KO160-10	Ø160	163	160	1000
KO160-15	Ø160	163	160	1500

PRODUCT DATA SHEET

Circular duct connector \varnothing 160 KO160-21

	\varnothing	Z
KO160-21	160	62

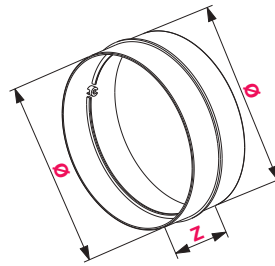

45° bend circular duct \varnothing 160 KO160-23/45

	\varnothing
KO160-23/45	160

For the correct installation of KO160-23/45, it is necessary to use the connector KO160-21 and place it between the elbow and the duct section according to the following diagram.

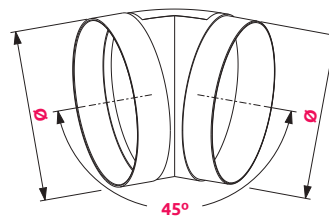

45 - degree bend circular ducts can be joined together and rotated in any direction up to 360 degrees.

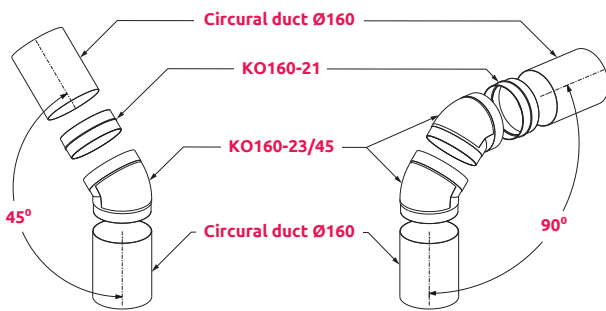

Circular duct clamp \varnothing 160 KO160-28

	$\varnothing 1$	$\varnothing 2$
KO160-28	150-170	8

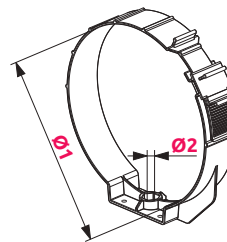

Circular duct reductor \varnothing 160/150 KO160-29

	$\varnothing 1$	$\varnothing 2$
KO160-29	160	150

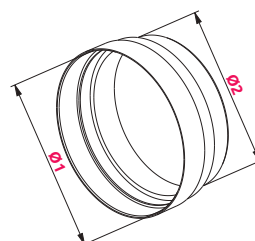

Flexible duct with thermal insulation

KEI160, KEI200, KEI250, KEI315

Insulated ventilation ducts with temperature resistance up to 140°C. They are designed for ventilation, air conditioning and heat recovery systems. Adequate stiffness and maintenance of the cross-section are ensured by an internal duct frame made of spiral wound steel wire with increased strength. They are excellent at dampening noise, eliminating vibration, and reduce the need for fittings.

Available in length 5 and 10 meters.



Material: Aluminium

Operating temperature range: -30°C / +140°C

Air velocity: max. 30m / sec.

Operating pressure: max. 5000 Pa

Flammability class: fire-retardant

Insulation: wool with a thickness of 25 mm and density of 12 kg/m³

Outer cladding: Aluminium

INDEX	Ø	lm.	INDEX	Ø	lm.
KEI160	Ø160	10	KEI160-50	Ø160	5
KEI200	Ø200	10	KEI200-50	Ø200	5
KEI250	Ø250	10	KEI250-50	Ø250	5
KEI315	Ø315	10	KEI315-50	Ø315	5

AIR FLOW CHARACTERISTICS

Air flow velocity	KEI160			KEI200			KEI250			KEI315		
	2 [m/s]	2,5 [m/s]	3 [m/s]	2 [m/s]	2,5 [m/s]	3 [m/s]	2 [m/s]	2,5 [m/s]	3 [m/s]	2 [m/s]	2,5 [m/s]	3 [m/s]
Duct length	Pressure drop [Pa]			Pressure drop [Pa]			Pressure drop [Pa]			Pressure drop [Pa]		
1 lm	0,8	1,2	1,6	0,8	1,2	1,8	0,4	0,6	0,8	0,3	0,6	1,0
2 lm	1,5	3,5	3,2	1,7	3,5	3,6	0,8	3,5	1,6	0,6	3,5	2,1
4 lm	3,1	4,9	6,5	3,4	5,0	7,1	1,5	2,2	3,2	1,2	2,2	4,1
6 lm	4,6	7,3	9,7	5,0	7,4	10,7	2,3	3,3	4,8	1,9	3,3	6,2
8 lm	6,2	9,8	13,0	6,7	9,9	14,2	3,0	4,4	6,4	2,5	4,4	8,2
10 lm	7,7	12,2	16,2	8,4	12,4	17,8	3,8	5,5	8,0	3,1	5,5	10,3
12 lm	9,2	14,6	19,4	10,1	14,9	21,4	4,6	6,6	9,6	3,7	6,6	12,4
14 lm	10,8	17,1	22,7	11,8	17,4	24,9	5,3	7,7	11,2	4,3	7,7	14,4
16 lm	12,3	19,5	25,9	13,4	19,8	28,5	6,1	8,8	12,8	5,0	8,8	16,5
18 lm	13,9	22,0	29,2	15,1	22,3	32,0	6,8	9,9	14,4	5,6	9,9	18,5
20 lm	15,4	24,4	32,4	16,8	24,8	35,6	7,6	11,0	16,0	6,2	11,0	20,6

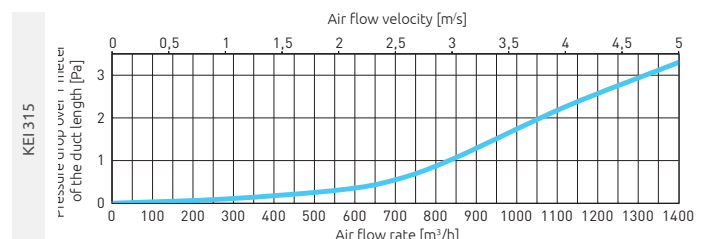
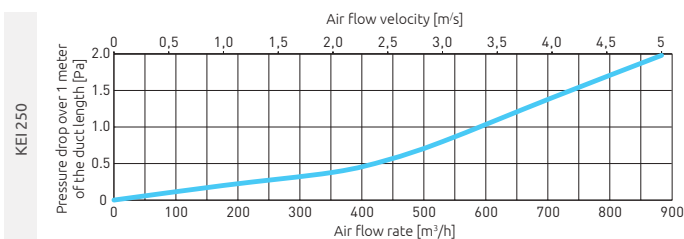
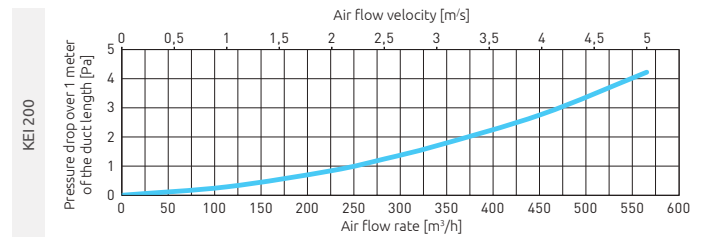
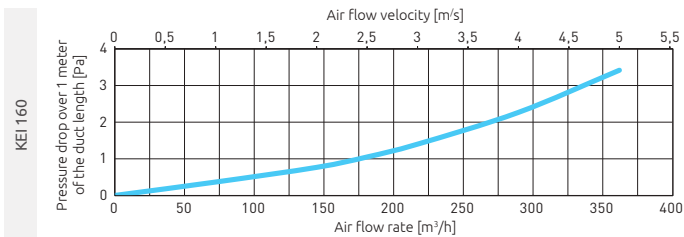

PRODUCT DATA SHEET

Airflow regulator \varnothing 75 VRP75-10G

	$\varnothing 1$	$\varnothing 2$	Z			
VRP75	70	59	8,1			
Number of removed rings	Air flow velocity [m ³ /h]					
	10	20	30	40	50	60
	Pressure drop [Pa]					
	0	9,0	31,6	69,1	119,8	186,2
1	6,0	21,4	45,9	81,3	126,9	183,0
2	3,3	12,2	26,8	46,6	71,7	104,7
3	1,5	5,8	12,9	22,7	36,1	53,5
4	0,4	1,8	3,9	7,1	11,1	17,0
5	0,2	0,5	1,0	1,9	2,9	4,0

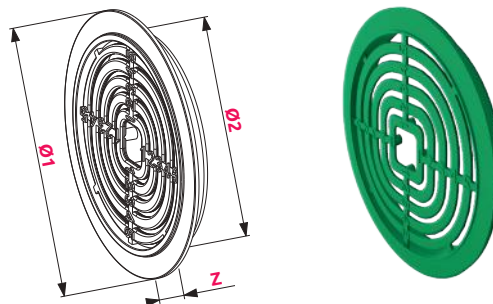

Coupling

VM75, VM90

The couplings provide fast, durable and break-resistant duct connections.

Available diameters: \varnothing 75, \varnothing 90



End caps

Z75-5, VZ90-5

End caps protect ducts from any contamination during transport, storage and the system from possible contamination during installation.

Available diameters: \varnothing 75, \varnothing 90



Gaskets

VU75-5, VU90-5

Specially designed gaskets ensure a tight connection between ducts as well as between duct and manifolds and plenum boxes.

Available diameters: \varnothing 75, \varnothing 90



Duct cutter \varnothing 75, 90

VNK75R, VNK75G, VNK90R, VNK90G

A cutter for ducts with a diameter of 75-90 mm, with replaceable blades.

Available diameters: \varnothing 75, \varnothing 90



Mounting tape, perforated

VTM

It is ideal for installations requiring smooth height adjustment or when there is no possibility to use clamps.

Mounting openings of \varnothing 4 mm and 8 mm



Tape for the VZO band clamp

The metal tape allows you to create band clamps of any diameter. Special packaging makes it easy to measure the desired lengths of tape

Width: 9 mm, thickness: 0.6 mm, Length: 30 mb.



Sealing tape

VTA (aluminium), TTT (reinforced)

Sealing tape is used to protect connections from possible leaks.

Available diameters: \varnothing 75, \varnothing 90



Duct holder \varnothing 75

VH75-2

Duct holder with a diameter of 75 mm. The holder allows you to instal the ducts both on the floor and the ceiling.





Wi-Fi



30 000 H



IP RATING

Decentralized ventilation

Decentralized ventilation ensures comfort by supplying the optimal amount of fresh air without the need to open windows, which results in significant cooling of the room in winter and the influx of insects in summer. The ventilation system consists of several smaller units located in different rooms of the house.

Thanks to the use of energy-efficient fans and high-efficiency heat exchangers, the installation of AHR devices also brings economic benefits.

Heat recovery takes place through the two-way operation of the devices. During the exhaust cycle, the used air flows through the heat exchanger, which collects its thermal energy, while during the supply cycle, the heat accumulated in the heat exchanger is collected and then transferred to the room. The use of temperature hysteresis eliminates frequent switching between operating modes. Ventilation responds to actual temperature changes rather than the passage of time, which increases energy efficiency and user comfort. The length of the cycle depends on temperature measurement only in the AHR PLUS version. An additional aspect is the reduction of interference with the building compared to a traditional recuperation system. The devices are located directly in the external wall of the building, without the need for ventilation ducts or major renovation work. This significantly reduces installation costs, especially in older buildings.



Exhaust grille/intake grille to decentralized AHR unit

A dedicated air intake and exhaust grilles designed for outdoor installation is available for AHR decentralized ventilation systems. The product has been designed for outdoor use. Its construction ensures resistance to weather conditions. The solution allows for aesthetic and orderly installation through a building partition.

They are not standard equipment for AHR devices. They can be used depending on project requirements and local conditions.

The product is intended for outdoor use. The installation of the components facilitates the maintenance of the correct air flow direction. The solution supports the correct operation of the ventilation system.



WHITE

GRAPHITE

DIMENSIONS

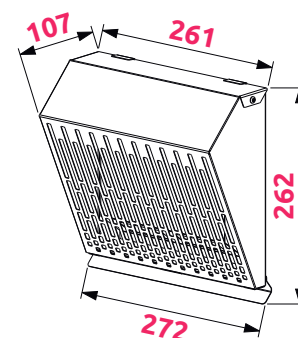

AHR

AHR is a new generation of decentralized ventilation devices facilitating ventilation while reducing heat loss.

Thanks to the use of an accumulation heat exchanger, the AHR retains and stores heat energy to transfer it to the cooler, supplied air. The applied electronics control the operation of the device and adjusts its parameters depending on the conditions in the room where the AHR is installed.

In addition, the AHR series has possibility to pair multiple devices thanks to automatic wireless communication.



1 The ceramic exchanger

9 LED display

6 Remote Control

7 Automatic shutters



Wi-Fi



30 000 H



IP RATING

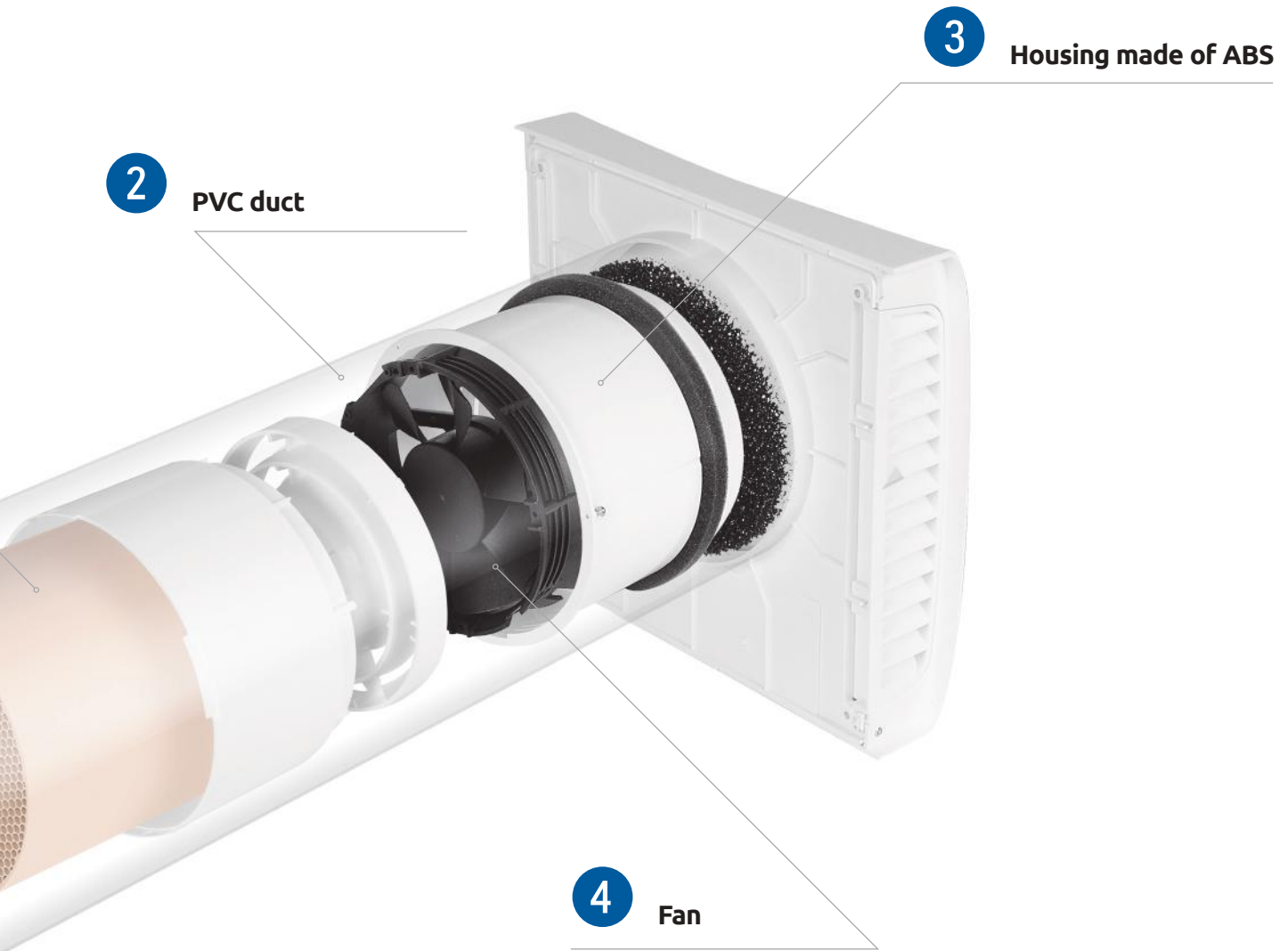

5 Filters

8 Temperature and humidity sensor



AHRP160 PLUS

AHRP160

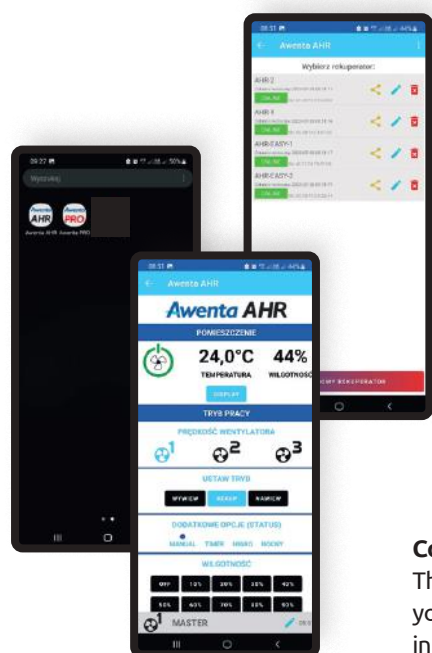

Awenta AHR app available on **Android** and **iOS**.

With the mobile app you can remotely manage your AHR family fans without the need for a remote control.

Comprehensive application

The extensive virtual control panel allows you to manage the functions of the AHR160 in detail..

	I	II	III
dB (A)	24	34	39
m ³ /h	23	36	52
W	4	5	7

Filtr G3



G3 class filter included

Functionality of the application:

Switching on/off

Current temperature

Current humidity

Gear shift

Recuperation mode

Supply air mode

Exhaust mode

Hygro mode

Timer mode

Synchronised operation - info+activation

Night mode (time setting + activation)

Time to filter change

Reset time to filter change

Remote timer setting on the unit

Info master/slave

Info current gear

EQUIPMENT



Wi-Fi



Terminal block



3 speed



Remote Controller



Timer



Humidity sensor



BALL BEARINGS



4 RAWLPLUGS AND SCREWS

DIMENSIONS

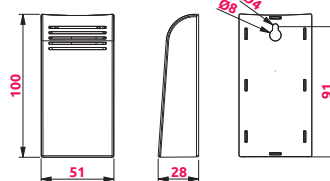
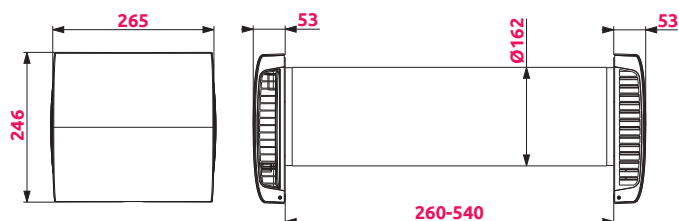



30 000 H



IP RATING



1 The ceramic exchanger is the heart of the device and one of its most important elements. In AHR, a hexagonal exchanger was used, thanks to which one of the highest heat recovery rates in decentralized ventilation devices available on the market was obtained.



2 Duct was made of PVC with addition of silver ions to prevent proliferating of bacteria inside of it. Additional insulation was used to reduce condensation and heat loss.



3 Main components are made of ABS plastic with addition of UV stabilizer increasing resistance to sunlight.



4 Energy - saving brushless motor 24V DC.



5 The AHR is equipped with two air purifying filters.



6 The AHRP160 is equipped with an infrared remote control, enabling the device to be operated in the full range of changing operating modes, operating speed as well as switching on and off.



7 Automatic shutters that cut off the air flow when the device is turned off and a soundproofed internal panel increase the comfort of use.



8 The wireless temperature and humidity sensor enables automatic operation of the device, which, based on the measurements, adjusts the operating speed.



Additional filter: G3 class. Included as standard.



For thick walls it is possible to obtain longer isolation duct AHR160KO-075 at length 750 mm.



9

Display mode 1
The display is dimmed (a blinking dot indicates active ventilation, continuous light indicates off mode)

Display mode 2
Display is showing the air flow direction, set gear and current room humidity level

Display mode 3
Display is showing the air flow direction, set gear and current room temperature

Display mode 4
The current time is displayed

Display mode 5
Sequential change of display modes (2, 3, 4) every 5 seconds

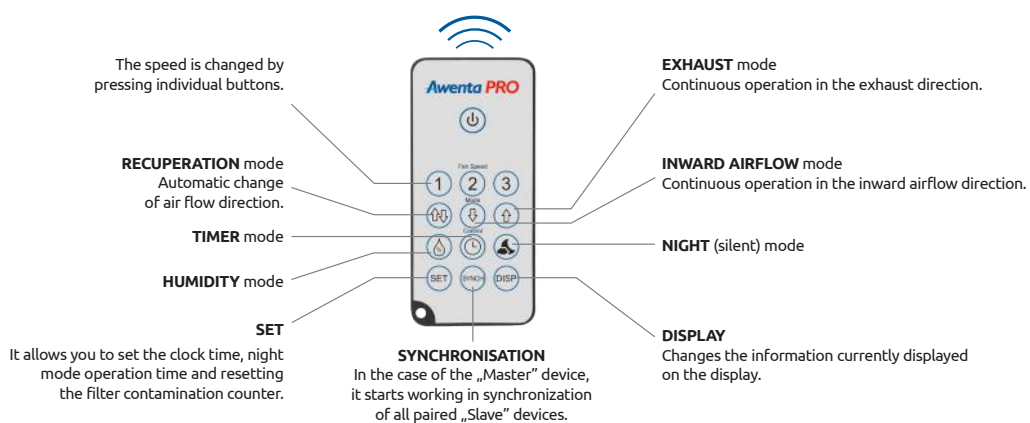

RECUPERATION mode
The air flow direction is changed automatically based on the measurement temperature.



AIR SUPPLY / EXHAUST mode
Continuous operation in the inward or exhaust airflow direction at the room.



HUMIDITY mode
The speed depends on the settings and currently measured humidity.



TIMER mode
Enables automatic shutdown of the device after 5-180 minutes.



NIGHT (silent) mode
The night mode is activated at the user-set clock time, reducing the efficiency of the device.

AHRE160 EASY

AHRE160

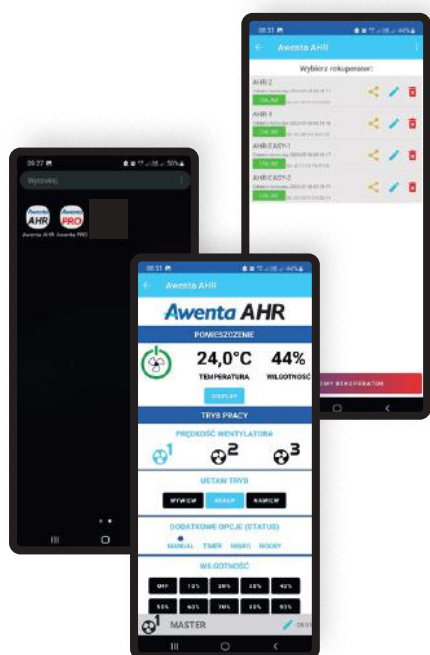

Awenta AHR app available on **Android** and **iOS**.

With the mobile app you can remotely manage your AHR family fans and external temperature, humidity sensor* without the need for a remote control.

EASY TO USE

The simplified interface allows quick and easy management of the AHR160 Easy and external temperature and humidity sensor*.

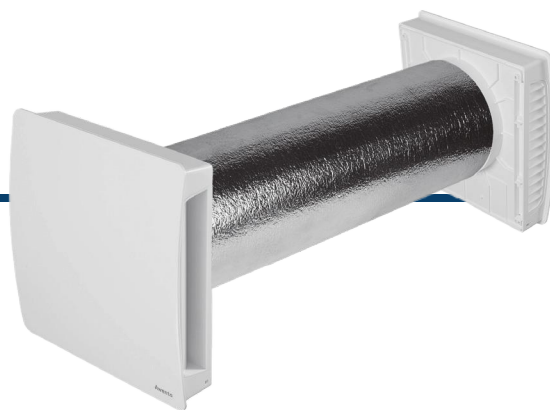

I	24 dB (A)	23 m ³ /h	4 W
II	34 dB (A)	36 m ³ /h	5 W
III	39 dB (A)	52 m ³ /h	7 W

*optional product, sold separately

Functionality of the application:

Master mode

- Switching on / off
- Gear shift
- Recuperation mode
- Supply air mode
- Exhaust mode
- Night mode (OFF or 8h)
- Ventilation mode (OFF or 30min)
- Synchronised operation - info
- Time to filter change
- Reset time until filter change
- Info Master/Slave
- Info current gear

Slave mode

- Information on synchronisation operation
- Time until filter change
- Reset of time until filter change
- Info Master/Slave
- Info of current gear

EQUIPMENT



Wi-Fi



Terminal box



3 speed



Remote controller

DIMENSIONS

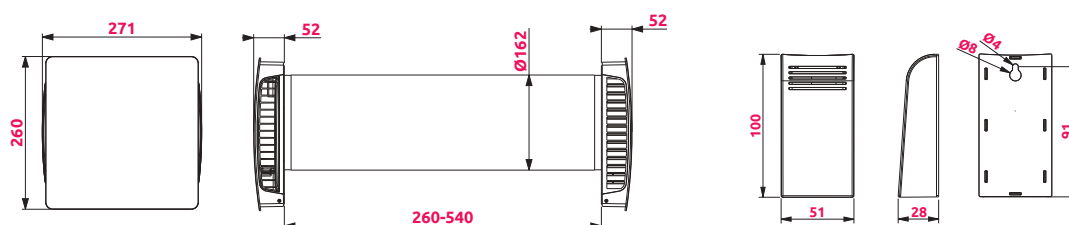

BALL BEARINGS



4 RAWLPLUGS AND SCREWS



30 000 H



IP RATING



1 The ceramic exchanger is the heart of the device and one of its most important elements. In AHR, a hexagonal exchanger was used, thanks to which one of the highest heat recovery rates in decentralized ventilation devices available on the market was obtained.



2 Duct was made of PVC with addition of silver ions to prevent proliferating of bacteria inside of it. Additional insulation was used to reduce condensation and heat loss.



3 Main components are made of ABS plastic with addition of UV stabilizer increasing resistance to sunlight.



4 Energy - saving brushless motor 24V DC.



5 The AHR is equipped with two air purifying filters.



6 The AHRE160 is equipped with an infrared remote control, enabling the device to be operated in the full range of changing operating modes, operating speed as well as switching on and off.



7 Automatic shutters that cut off the air flow when the device is turned off and a soundproofed internal panel increase the comfort of use.



8 The wireless temperature and humidity sensor enables automatic operation of the device, which, based on the measurements, adjusts the operating speed.

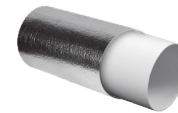

For thick walls it is possible to obtain longer isolation duct AHR160KO-075 at length 750 mm.

*optional product sold separately

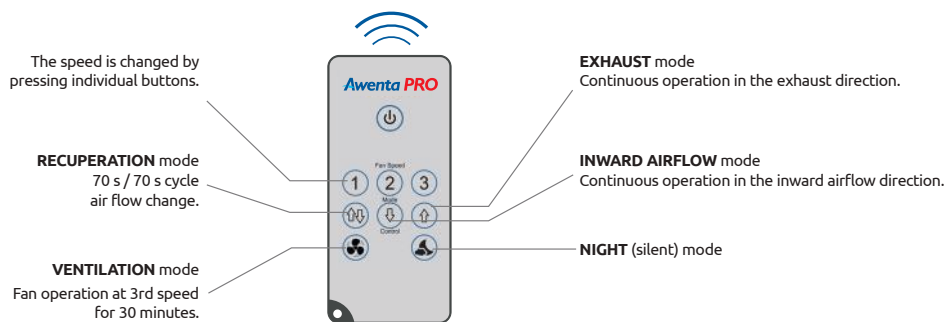

RECUPERATION mode
The direction of airflow is changed every 70 seconds.



AIR SUPPLY / EXHAUST mode
Continuous operation in the inward or exhaust airflow direction at the room.



NIGHT (silent) mode
The night mode is activated for 8 clock hours, reducing the efficiency of the device



VENTILATION mode
Fan operation at 3rd speed for 30 minutes in the currently selected direction (mode)
Switching off by pressing the remote control button again or when changing to a speed other than 3rd.

AHR160 PLUS, AHR160 EASY

AHRP160, AHRE160

The AHR series has the ability to connect several devices installed in one or more rooms with the possibility of pairing them via wireless communication. No hassle of connecting devices with a power cord.

Connection possible in various modes, e.g. both units only supply or only exhaust and alternate operation, one unit blows in and the other blows out.

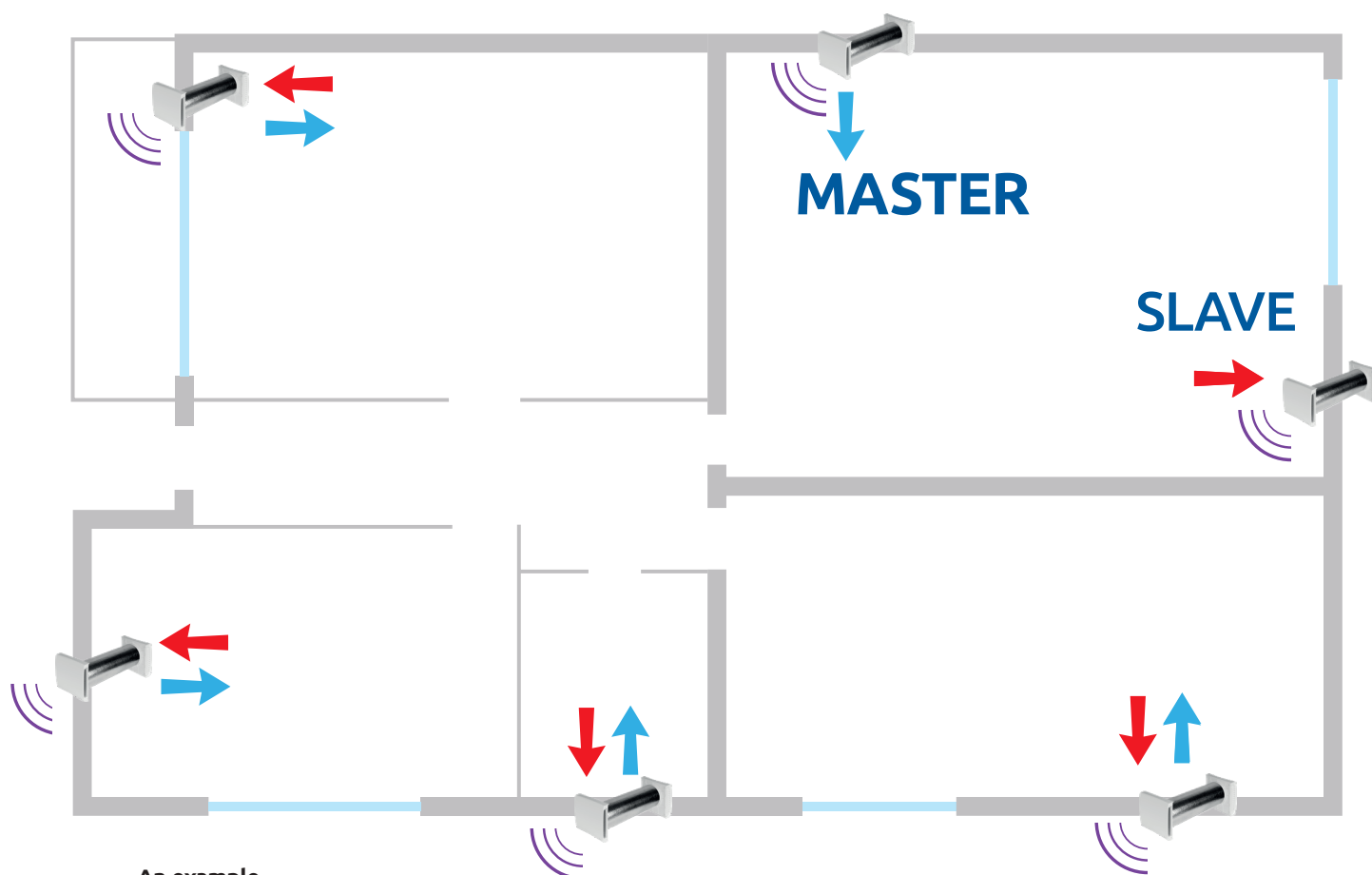
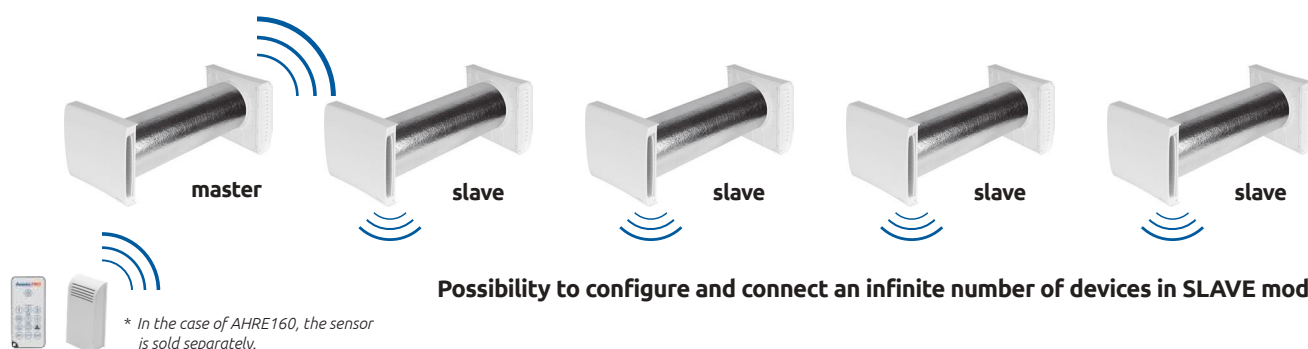

An example of AHR devices arrangement



30 000 H



IP RATING

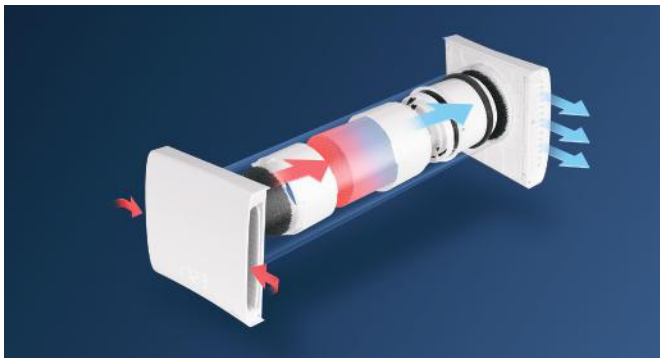

EXHAUST

During exhaust operation, the heat is stored in a ceramic heat exchanger. After the exchanger is completely warmed up, it automatically changes the direction of operation.

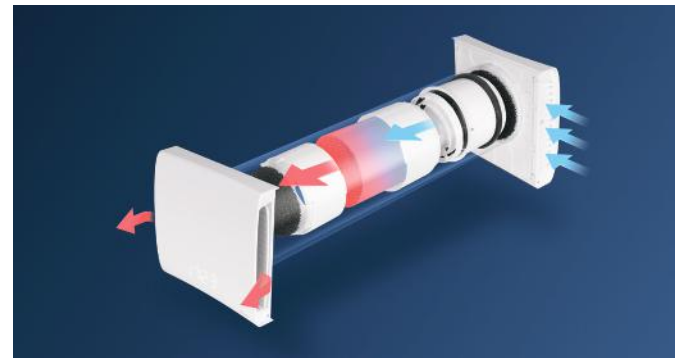

AIR FLOW

The heat accumulated in the exchanger is collected by the supply air stream and then transferred to the room. After the exchanger cools down, it automatically changes the direction of operation.

The optimal one-way operation time is determined by the temperature readings from sensors located upstream and downstream of the heat exchanger.

The principle of AHR devices operation

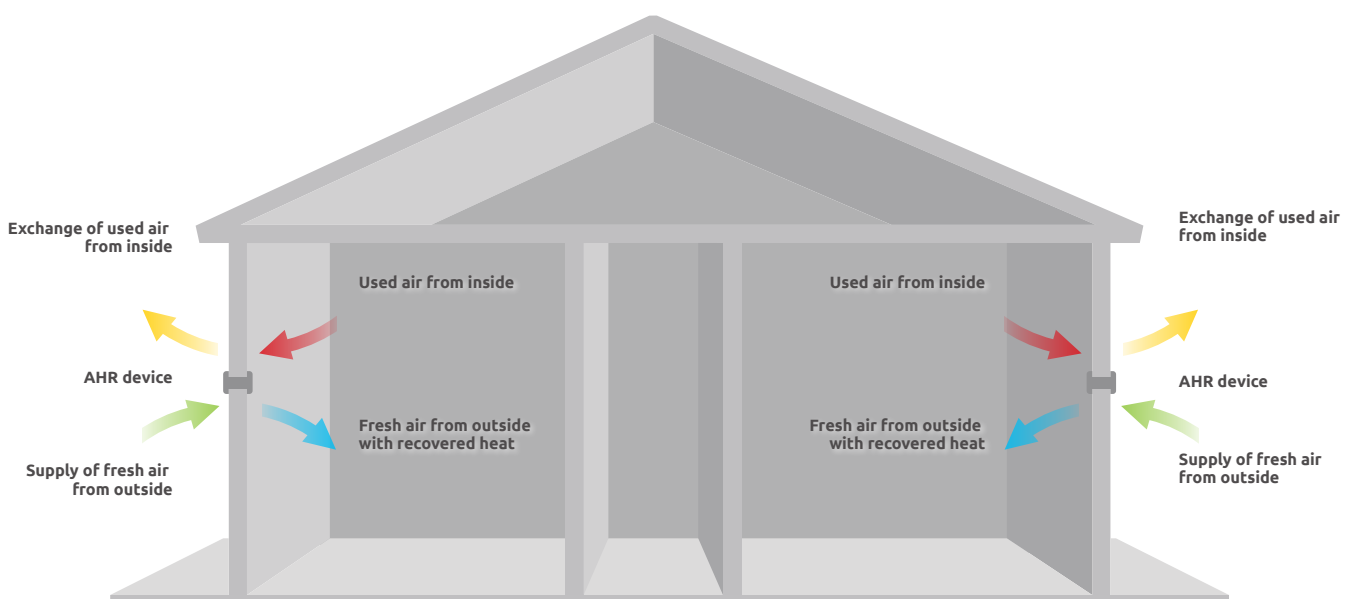

Awenta Spółka Jawna
05-300 Mińsk Mazowiecki
Stojadła, Warszawska 99 St.
Poland

tel: +48 25 758-52-52
+48 25 758-93-92

e-mail: export@awenta.pl

awenta.pl/en/pro

